

Quarry Specification Excavators

**ZAXIS R series**

**ZAXIS470R/670R/870R**



**HYDRAULIC EXCAVATOR**

Model Code : ZX470R-5G / ZX470LCR-5G / ZX670LCR-5G / ZX870LCR-5G

Engine Rated Power : ZX470R-5G / ZX470LCR-5G : 235 kW (315 HP)

ZX670LCR-5G : 312 kW (418 HP) / ZX870LCR-5G : 360 kW (483 HP)

Operating Weight : ZX470R-5G : 46 400 kg / ZX470LCR-5G : 47 600 kg

ZX670LCR-5G : 69 300 kg / ZX870LCR-5G : 85 800 kg

Backhoe Bucket : ISO Heaped :

ZX470R-5G : 1.90 - 2.30 m<sup>3</sup> / ZX470LCR-5G : 1.90 - 2.50 m<sup>3</sup>

ZX670LCR-5G : 2.90 - 3.30 m<sup>3</sup> / ZX870LCR-5G : 3.50 - 4.30 m<sup>3</sup>

# ZAXIS Empower your Vision.

A ZAXIS hallmark – industry-leading hydraulic technologies, and performance no other can beat. New ZAXIS provides reliable solutions: impressive fuel economy, swift front movements, and easy operation. You'll also find Hitachi technological prowess and expertise, such as the optimized hydraulic system and engine. New ZAXIS features the key benefits of high quality, low fuel consumption, and high durability, all of which serve to ensure low running costs. New ZAXIS, which is empowered by comprehensive evolution, will realize customers' visions and dreams, and pioneer your colorful future.



Model : ZAXIS 470LCR



## Pursuits of Performance and Durability Powerful in Quarry

Page 4-5

- The required strength and durability for customer satisfaction
- Prestige R&D and quality control
- R-bucket
- Specially designed front attachment for quarry
- Tougher undercarriage for rocky ground condition

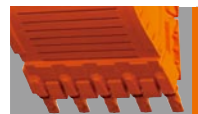

## Large Production with Less Fuel

Page 6-7

- Reduction in fuel consumption
- Durable, reliable engine
- Swift front movements with HIOS IIIB hydraulics
- Enhancement in swing torque
- Easy-to use attachments
- Applicable for breaker operation (Optional)



## No Compromise on Operator Comfort

Page 8

- Comfortable operating environment
- Comfort-designed operator seat
- H/R cab
- New, easy-to-use multifunction monitor



## Simplified Maintenance

Page 9

- Useful inspection points
- Fast lubrication
- Easy-access to the upperstructure



## Hitachi Support Chain

Page 10-11

- Remote fleet management with Global e-Service
- Parts and service



Model : ZAXIS 470LCR

# Pursuits of Performance and Durability Powerful in Quarry

## The Required Strength and Durability for Customer Satisfaction

- Beating the competition with exclusive design for quarries and limestone mines using a wealth of experience
- Increasing durability by strengthening the undercarriage, boom and arm on the H-specification machine
- Buckets are exclusively developed and built for quarries and limestone
- H/R cab provided with fixed front straight-laminated glass window

## Prestige R&D and Quality Control

Hitachi has earned praise for technological prowess and product performance around the world. R&D Division has a track record – including excellent design, stress analysis expertise using CAE system, and abundant production database. What's more, a large-scale durability test field (427 hm<sup>2</sup>) allows for a series of stringent testing of new machines. Production Division strives to automatize production processes, including robotic welding, machining, painting, assembling and transferring.



## Specially Designed Front Attachment for Quarry

The boom-end rigidity through the use of a thick single plate and increased boomend bushing thickness also contribute increasing durability. Reinforced arm-end boss and arm cylinder mounting bracket provides higher durability. Protection plate with 5-square bars also enhances reliability in heavy duty operation.

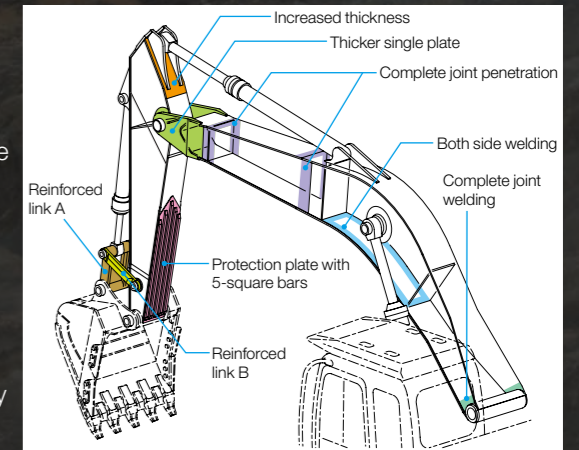

## R-Bucket

The R-bucket is made of wear resisting steel, and reshaped with side shrouds, cutting-edge shrouds, and large bucket teeth for enhanced durability. Easily replaceable lateral wear plates help reduce downtime. The limestone bucket has similar features except number of side shrouds and size of tooth.

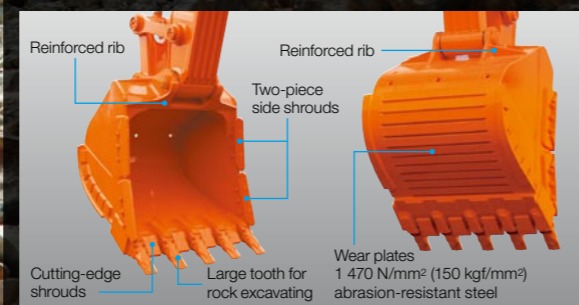

## Tougher Undercarriage for Rocky Ground Condition

The reinforced travel motor cover with square bars and reinforced travel guard protect travel motor from damage by stone projectiles. Rigid structure of side frame withstands frequent shock caused by rock hitting. Track under cover (Optional) protects travel pipings and hoses. Full track guards protect track links and lower rollers from damage and deformation. Moreover, they also keep out stones, preventing overload to the undercarriage to reduce wear and damage.

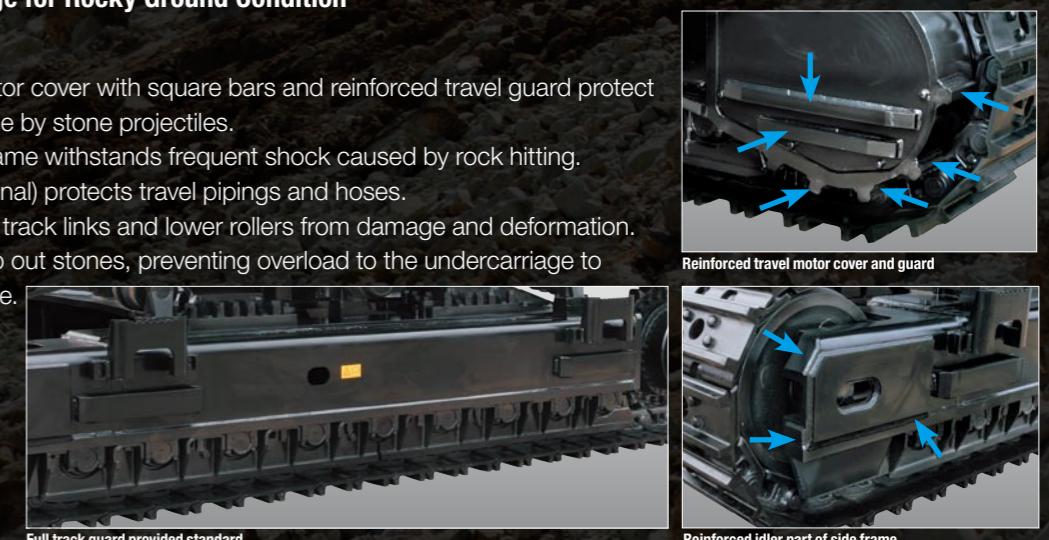

Photos and illustration show ZAXIS 870LCR.

How to strengthen bucket, boom, arm and undercarriage according to the model.

# Large Production with Less Fuel

## Reduction in Fuel Consumption

New ZAXIS is a fuel-thrifty excavator that can reduce fuel consumption. Thanks to the HIOS III B hydraulic system and engine control system, thereby reducing CO2 emissions.

- ZX470R-5G / ZX470LCR-5G : 9%\*
- ZX670LCR-5G : 6%\*
- ZX870LCR-5G : 4%\*

\*H/P mode vs. conventional model's H/P mode.

## Durable, Reliable Engine

This engine has a track record showing impressive durability at countless tough job sites around the world.

The engine — associated with a rugged design, a direct fuel injection system and an elaborate governor — goes green, and complies with EU Stage II and US EPA Tier 2 emissions regulations.

The combination of a engine and the new HIOS III B hydraulic system meets requirements, in terms of both output and fuel consumption.



ZAXIS 470R / 470LCR



ZAXIS 670LCR / 870LCR

## Swift Front Movements with HIOS\* IIIB Hydraulics

Operating speed increases with less fuel consumption thanks to the HIOS III B hydraulic system, developed by industry-leading hydraulic technologies and a wealth of experience.

\*Human & Intelligent Operation System.

## Improved Arm Controllability

Improved arm controllability for level luffing and level crowding for front movements, including swing operations. The boom regenerative circuit using the boom weight and the newly adopted variable orifice of the swing circuit, help ensure hydraulic oil can be effectively allocated and pressure loss can be reduced.



Model : ZAXIS 870LCR

## Enhancement in Swing Torque

One of the key performance requirements for mining machinery is swing power. It must be capable of holding and swinging buckets full of crushed stones powerfully, and then loading them onto a dump truck. The new ZAXIS adopts a newly developed swing device to improve swing power by 9%\* over conventional models. It also has sufficient capacity to load crushed stones onto a dump truck.

- ZX470R-5G / ZX470LCR-5G : 8%\*
- ZX670LCR-5G : 9%\*
- ZX870LCR-5G : 9%\*

\*Compared to the conventional model.

## Easy-to-Use Attachments

The operator can change over valves (ZAXIS 470 family only), adjust extra circuit flow and check settings from the multifunction monitor next to the operator seat. What's more, 11 jobs, including flow rate setting, can easily be selected by their identified names.



Model : ZAXIS 870LCR

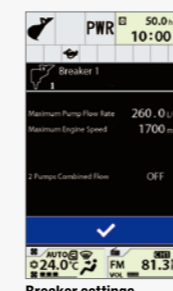

Breaker settings

## Applicable for Breaker Operation (Optional)

### Double Accumulator

Double accumulator protects hydraulic pumps from pulse beat from breaker.

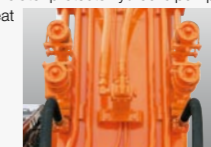

### Hour Meter for the Breaker

With the new ZAXIS, the number of hours that the breaker has been used for can be displayed on the multi function monitor. In addition, since the breaker operation hours and working ratio can be viewed, the operator can verify the time when the hydraulic oil and filter should be replaced. (with resettable trip function)

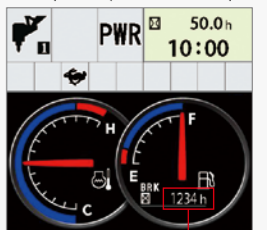

Breaker hour meter

### Ergonomic breaker pedal layout

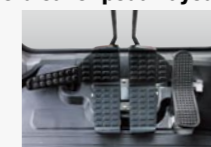

### Shatterproof windshield and window

Laminated film on the front windshield and right side window to prevent shattering.

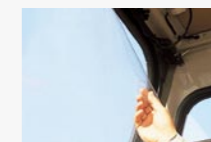

## No Compromise on Operator Comfort



The photo shows an optional air suspension seat.

### Comfortable Operating Environment

You'll feel comfortable and confident, with plenty of leg space and excellent visibility. The new compact console gives more leg space. The new door pillar is shifted rearward by 70 mm to widen an entry space for easy access. A new LED room light, interlocked with the door, turns on when the door opens. Ample air conditioner vents are located strategically for uniform air circulation inside the cab. The control panel and control levers are arranged within easy reach of the operator. AUX port (Optional) for a mobile music player are available for a long work day with less fatigue. All these designs focus on operator comfort.

### Comfort-Designed Operator Seat

The luxury cloth seat is fitted with a headrest and arm rests for operator comfort. The seat can be adjusted in multiple ways, sliding and reclining, to suit operator's size and preferences. The seat can slide rearward by 40 mm more for added leg space. An air suspension with a heat pad is optional.

### H/R Cab

The H/R cab, meeting the OPG (Top Guard Level II), protects the operator from falling objects. The pilot control shut-off lever is provided with the neutral engine start system that permits engine starting only when the pilot control shut-off lever is in Lock position. The engine is lockable by entering a password through the 10-key panel.

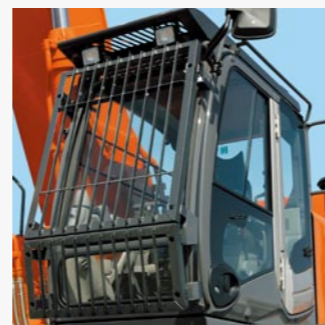

\*Front guard (upper and lower) is optional.

## Simplified Maintenance



An air conditioner filter for fresh air



### Useful Inspection Points

Inspection points with three models, which are arranged according to the machine layout. A lid behind the cab door is available for easy replacement of the air conditioner filters for fresh air.

### Fast Lubrication

The arm and boom have their own centralized greasing points for fast lubrication. An optional electric grease gun with hose-reel or an auto-grease lubricator is also available for faster greasing / lubrication.

### Easy-Access to the Upperstructure

A large sidewalk is provided on the left side of the cab, making it easy to access the engine and inspection points. Anti-slip steps and handrail are provided for safety.

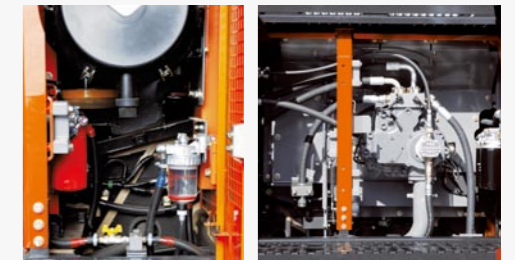

Inspection points on the right cover Inspection points on the left cover



Sidewalk



Centralized boom and arm greasing points Electric grease gun with hose-reel (Optional)

Photos show ZAXIS 470R series.

### New, Easy-to-Use Multifunction Monitor

The new multi-language, multifunction monitoring system comprises of a 7-inch high-resolution color monitor and a multifunction controller. The monitor allows the operator to check varying operating variables: hydraulic oil temperature, fuel level, work mode, full-auto air conditioner, AM/FM radio, rear view monitor camera (Optional), maintenance support, and attachment flow adjustment. Menu items can be selected and adjusted by a multifunction controller on the control panel. A new rear view monitor camera always displays the view behind the machine.

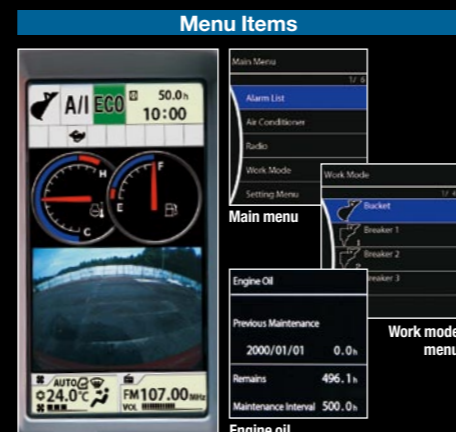

# Hitachi Support Chain

Hitachi Support Chain is a full customer support system offered after buying a Hitachi machine.

## Remote Fleet Management with Global e-Service

### Easy Access to On-Site Machines through the Internet

This on-line fleet management system allows you to access each on-site machine from a PC in your office. You can get its operating information and location to increase productivity of the fleet and reduce downtime. Operating data and log are sent to a Hitachi server for processing, and then to customer and dealers around the world. This system is available 24 hours a day, all the year around.

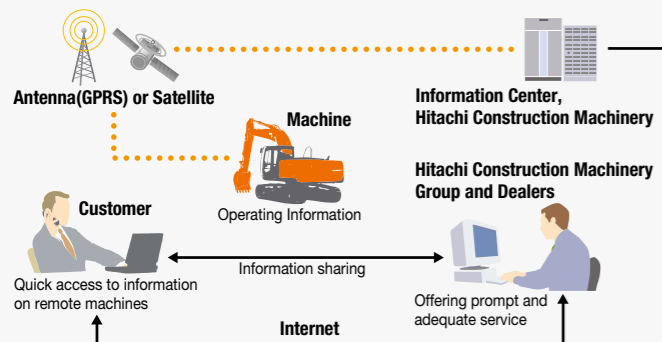

Note: In Some Regions, Global e-Service Is Not Available by Local Regulations.

### Main Features of Global e-Service

#### Functions

Global e-Service provides easy access to a machine on site, conveying operating information and log, including daily operating hours, fuel level, temperatures, pressures, and the likes.

#### Maintenance

Maintenance data and log are displayed on a easy-to-read monitor screen, suggesting recommended maintenance for efficient fleet management.

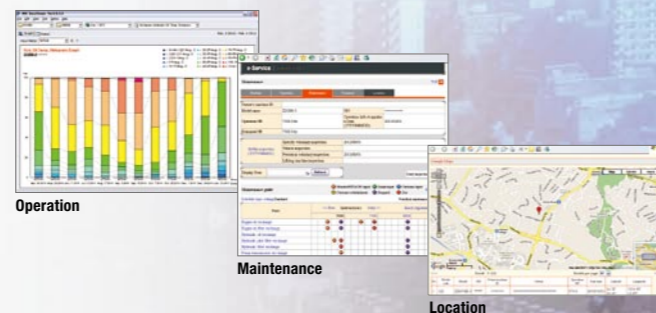

## Parts and Service

Hitachi full customer support is available every area on the globe for full customer satisfaction through Hitachi local dealers.

### Parts

Hitachi Global Online Network, a parts supply system, is linked with Japan Parts Center, overseas depots and over 150 dealers abroad to deliver on-line parts information, including in-stock parts, order receptions, shipments and delivery period of over one million parts and components.

#### Genuine Hitachi Parts

Genuine Hitachi parts, meeting Hitachi stringent quality standards, are guaranteed according to Hitachi warranty standards. The use of genuine Hitachi parts, including engine, fuel, hydraulic oil and filters, may slash running costs, and extend machine life.

#### Ground Engaging Tools (GETs)

Hitachi provides an array of Hitachi Ground Engaging Tools developed and built for a variety of applications.

Using high-quality, well-maintained GETs will help you get customers' trust.

Note: Some dealers do not handle Hitachi GETs.

#### Remanufactured Components

Hitachi components are remanufactured according to the stringent remanufacturing standards at four factories around the world. They have high quality equivalent to new ones, and backed up by Hitachi warranty system.

Note: Some dealers do not handle Hitachi Remanufactured Components.

### Service

#### Extended Warranty — HELP

Hitachi Standard Warranty System is available on all new Hitachi machines. In addition, Hitachi offers Hitachi Extended Life Programs (HELPS) to suit customer expectations –

protecting machines under tough operating conditions, avoiding unexpected downtime, and reducing repair costs.

Note: Warranty conditions vary by equipment.

#### Diagnostic Tools — Maintenance Pro

Electronic control system needs quick on-site solutions, apart from mechanical repairs. Hitachi's Maintenance Pro can diagnose machine failures in a short time by plugging a PC into a failed machine.

#### Technical Training

On-site servicing matters despite locations to keep the machine at peak performance and reduce downtime. Technical Training Center (TTC), located in Japan, educates and trains service technicians and service support personnel coming from Hitachi dealers and factories on the globe according to the international training programs.

# SPECIFICATIONS

ENGINE			
	ZX470R-5G / ZX470LCR-5G	ZX670LCR-5G	ZX870LCR-5G
Model	Isuzu AA-6WG1TQA	Isuzu BB-6WG1XQA-05	Isuzu BB-6WG1XQA-04
Type	4-cycle water-cooled, direct injection		
Aspiration	Turbocharged	Turbocharged, intercooled	
No. of cylinders	6		
Rated power			
ISO 9249, net	H/P mode: 235 kW / 1 800 min <sup>-1</sup> (315 HP / 1 800 rpm) [Without Fan]	H/P mode: 312 kW / 1 800 min <sup>-1</sup> (418 HP / 1 800 rpm) [Without Fan]	H/P mode: 360 kW / 1 800 min <sup>-1</sup> (483 HP / 1 800 rpm) [Without Fan]
SAE J1349, net	H/P mode: 231 kW / 1 800 min <sup>-1</sup> (310 HP / 1 800 rpm) [Without Fan]	H/P mode: 312 kW / 1 800 min <sup>-1</sup> (418 HP / 1 800 rpm) [Without Fan]	H/P mode: 360 kW / 1 800 min <sup>-1</sup> (438 HP / 1 800 rpm) [Without Fan]
Maximum torque	1 275 Nm / 1 500 min <sup>-1</sup> (130 kgf m / 1 500 rpm)	1 621 Nm / 1 500 min <sup>-1</sup> (165 kgf m / 1 500 rpm)	1 945 Nm / 1 500 min <sup>-1</sup> (198 kgf m / 1 500 rpm)
Piston displacement	15.681 L	15.681 L	15.681 L
Bore and stroke	147 mm x 154 mm	147 mm x 154 mm	147 mm x 154 mm
Batteries	2 x 12 V / 170 Ah	2 x 12 V / 170 Ah	2 x 12 V / 170 Ah

HYDRAULIC SYSTEM			
	ZX470R-5G / ZX470LCR-5G	ZX670LCR-5G	ZX870LCR-5G
<b>Hydraulic Pumps</b>			
Main pumps	2 variable displacement axial piston pumps		
Maximum oil flow	2 x 360 L/min	2 x 443 L/min	2 x 512 L/min
Pilot pump	1 gear pump		
Maximum oil flow	30 L/min	50 L/min	50 L/min

<b>Hydraulic Motors</b>			
Travel	2 axial piston motors with parking brake		
Swing	2 axial piston motors		

Relief Valve Settings			
	ZX470R-5G / ZX470LCR-5G	ZX670LCR-5G	ZX870LCR-5G
Implement circuit	31.9 MPa (325 kgf/cm <sup>2</sup> )	31.9 MPa (325 kgf/cm <sup>2</sup> )	31.9 MPa (325 kgf/cm <sup>2</sup> )
Swing circuit	28.4 MPa (290 kgf/cm <sup>2</sup> )	29.4 MPa (300 kgf/cm <sup>2</sup> )	28.4 MPa (290 kgf/cm <sup>2</sup> )
Travel circuit	35.3 MPa (360 kgf/cm <sup>2</sup> )	34.3 MPa (350 kgf/cm <sup>2</sup> )	34.3 MPa (350 kgf/cm <sup>2</sup> )
Pilot circuit	3.9 MPa (40 kgf/cm <sup>2</sup> )	3.9 MPa (40 kgf/cm <sup>2</sup> )	3.9 MPa (40 kgf/cm <sup>2</sup> )
Power boost	35.3 MPa (360 kgf/cm <sup>2</sup> )	34.3 MPa (350 kgf/cm <sup>2</sup> )	34.3 MPa (350 kgf/cm <sup>2</sup> )

Hydraulic Cylinders									
	ZX470R-5G / ZX470LCR-5G			ZX670LCR-5G			ZX870LCR-5G		
	Quantity	Bore	Rod diameter	Quantity	Bore	Rod diameter	Quantity	Bore	Rod diameter
Boom	2	170 mm	115 mm	2	190 mm	130 mm	2	215 mm	150 mm
Arm	1	190 mm	130 mm	1	200 mm	140 mm	1	225 mm	160 mm
Bucket	1	170 mm	120 mm	1	180 mm	130 mm	1	200 mm	140 mm
Bucket BE	-	-	-	1	190 mm	130 mm	1	215 mm	150 mm

UPPERSTRUCTURE			
	ZX470R-5G / ZX470LCR-5G	ZX670LCR-5G	ZX870LCR-5G
Revolving Frame	D-section frame for resistance to deformation.		
Swing Device	Axial piston motor with planetary reduction gear is bathed in oil. Swing parking brake is spring-set/hydraulic-released disc type.		
Swing speed	9.0 min <sup>-1</sup> (rpm)	9.0 min <sup>-1</sup> (rpm)	7.4 min <sup>-1</sup> (rpm)
Operator's Cab (H/R cab)	Independent spacious cab, 1 025 mm wide by 1 817 mm high, The OPG top guard fitted Level II conforms to the related requirements of the International Organization Standardization(ISO)10262.		

UNDERCARRIAGE			
	ZX470R-5G / ZX470LCR-5G	ZX670LCR-5G	ZX870LCR-5G
Tracks	Track shoes made of induction-hardened rolled alloy. Heat-treated connecting pins with dirt seals. Hydraulic (grease) track adjusters with shock-absorbing recoil springs. Fitted with reinforced travel motor cover and idler part of side frame.		

### Numbers of Rollers and Shoes on Each Side

Upper rollers	2	3	3
Lower rollers	8 / 9	8	9
Track shoes	49 / 53	47	51
Full Track guard	1	1	1
Travel Device	Each track driven by axial piston motor through reduction gear for counterrotation of the tracks. Parking brake is spring-set/hydraulic-released disc type. Automatic transmission system: High-Low. The travel motor cover is reinforced with square bar for protection.		
Travel speeds	High / Low : 0 to 5.1 / 0 to 3.8 km/h	High / Low : 0 to 4.8 / 0 to 3.3 km/h	High / Low : 0 to 4.5 / 0 to 3.0 km/h
Maximum traction force	329 kN (33 600 kgf)	460 kN (46 900 kgf)	560 kN (57 100 kgf)
Gradeability	70% (35 degree) continuous		

SERVICE REFILL CAPACITIES			
	ZX470R-5G / ZX470LCR-5G	ZX670LCR-5G	ZX870LCR-5G
Fuel tank	705.0 L	920.0 L	1 110.0 L
Engine coolant	61.0 L	68.0 L	112.0 L
Engine oil	52.0 L	52.0 L	52.0 L
Pump device	-	6.2 L	6.2 L
Swing device (each side)	6.5 L	10.5 L	15.7 L
Travel device (each side)	11.0 L	16.0 L	19.0 L
Hydraulic system	510.0 L	750.0 L	1 042.0 L
Hydraulic oil tank	310.0 L	380.0 L	500.0 L

# SPECIFICATIONS

## WEIGHTS AND GROUND PRESSURE

### Operating Weight and Ground Pressure

#### ZX470R-5G / ZX470LCR-5G

Shoe type	Shoe width	Boom type	Arm type	ZX470R-5G		ZX470LCR-5G	
				kg	kPa (kgf/cm <sup>2</sup> )	kg	kPa (kgf/cm <sup>2</sup> )
Triple	600 mm	7.0 m R	3.4 m R	46 400	86 (0.88)	47 600	81 (0.82)
		Bucket capacity		1.90 m <sup>3</sup>		1.90 m <sup>3</sup>	
		7.0 m R	2.9 m BER	46 400	86 (0.88)	47 500	81 (0.82)
		Bucket capacity		2.10 m <sup>3</sup>		2.10 m <sup>3</sup>	
		6.3 m BER	2.9 m BER	46 300	86 (0.88)	47 600	81 (0.82)
		Bucket capacity		2.10 m <sup>3</sup>		2.30 m <sup>3</sup>	
		6.3 m BER	2.5 m BER	47 100	81 (0.83)	48 400	81 (0.83)
		Bucket capacity		2.30 m <sup>3</sup>		2.50 m <sup>3</sup>	

#### ZX670LCR-5G

Shoe type	Shoe width	Boom type	Arm type	kg	kPa (kgf/cm <sup>2</sup> )
Double	650 mm	7.8 m R	3.6 m R	69 300	104 (1.06)
		Bucket capacity		2.90 m <sup>3</sup>	
		6.8 m BER	2.9 m BER	69 200	104 (1.06)
		Bucket capacity		3.30 m <sup>3</sup>	

#### ZX870LCR-5G

Shoe type	Shoe width	Boom type	Arm type	kg	kPa (kgf/cm <sup>2</sup> )
Double	650 mm	8.4 m R	3.7 m R	85 800	117 (1.19)
		Bucket capacity		3.50 m <sup>3</sup>	
		7.1 m BER	3.7 m BER	85 300	116 (1.18)
		Bucket capacity		3.70 m <sup>3</sup>	
		7.1 m BER	2.95 m BER	86 200	117 (1.20)
		Bucket capacity		4.30 m <sup>3</sup>	

## BUCKET LIST

### ZX470R-5G / ZX470LCR-5G

Capacity	Width		No. of teeth	Weight	Recommendation			
					ZX470R-5G / ZX470LCR-5G			
					6.3 m BER-boom		7.0 m R-boom	
ISO heaped	Without side cutters	With side cutters			2.5 m BER-arm	2.9 m BER-arm	2.9 m BER-arm	3.4 m R-arm
1.90 m <sup>3</sup>	1 480 mm	1 500 mm	5	2 070 kg	● / ●	● / ●	● / ●	● / ●
2.10 m <sup>3</sup>	1 560 mm	1 580 mm	5	2 170 kg	● / ●	● / ●	● / ●	- / -
2.30 m <sup>3</sup>	1 680 mm	1 700 mm	5	2 260 kg	● / ●	- / ●	- / -	- / -
2.50 m <sup>3</sup>	1 800 mm	1 820 mm	5	2 360 kg	- / ●	- / -	- / -	- / -

### ZX670LCR-5G

Capacity	Width		No. of teeth	Weight	Recommendation	
					6.8 m R-boom	7.8 m R-boom
					2.9 m BER-arm	3.6 m R-arm
2.90 m <sup>3</sup>	1 680 mm	1 680 mm	5	3 300 kg	x	●
3.30 m <sup>3</sup>	1 790 mm	1 790 mm	5	3 610 kg	●	x

### ZX870LCR-5G

Capacity	Width		No. of teeth	Weight	Recommendation		
					7.1 m BER-boom		8.4 m R-boom
					2.95 m BER-arm	3.7 m R-arm	3.7 m R-arm
3.50 m <sup>3</sup>	1 870 mm	1 890 mm	5	4 870 kg	x	●	●
3.70 m <sup>3</sup>	1 950 mm	1 970 mm	5	4 970 kg	x	●	x
4.30 m <sup>3</sup>	2 090 mm	2 110 mm	5	5 690 kg	●	x	x

● R-bucket x Can't be installed - Not applicable

## BUCKET AND ARM DIGGING FORCE

### ZX470R-5G / ZX470LCR-5G

	ZX470R-5G		ZX470LCR-5G			
	7.0 m R-boom		6.3 m BE-boom		7.0 m R-boom	
	2.9 m BER-arm	3.4 m R-arm	2.5 m BER-arm	2.9 m BER-arm	2.9 m BER-arm	3.4 m R-arm
Bucket digging force* ISO	295 kN (30 150 kgf)	296 kN (30 260 kgf)	295 kN (30 150 kgf)	295 kN (30 150 kgf)	295 kN (30 150 kgf)	296 kN (30 260 kgf)
Bucket digging force* SAE : PCSA	266 kN (27 070 kgf)	257 kN (26 240 kgf)	266 kN (27 070 kgf)	266 kN (27 070 kgf)	266 kN (27 070 kgf)	257 kN (26 240 kgf)
Arm crowd force* ISO	263 kN (26 860 kgf)	224 kN (22 850 kgf)	302 kN (30 770 kgf)	263 kN (26 860 kgf)	263 kN (26 860 kgf)	224 kN (22 850 kgf)
Arm crowd force* SAE : PCSA	256 kN (26 140 kgf)	215 kN (21 920 kgf)	294 kN (30 050 kgf)	256 kN (26 140 kgf)	256 kN (26 140 kgf)	215 kN (21 920 kgf)

### ZX670LCR-5G

	6.8 m BER-boom	7.8 m R-boom
Arm length	2.9 m BER-arm	3.6 m R-arm
Bucket digging force* ISO	369 kN (37 700 kgf)	324 kN (33 100 kgf)
Bucket digging force* SAE : PCSA	332 kN (33 900 kgf)	286 kN (29 200 kgf)
Arm crowd force* ISO	306 kN (31 200 kgf)	255 kN (26 000 kgf)
Arm crowd force* SAE : PCSA	297 kN (30 300 kgf)	246 kN (25 100 kgf)

### ZX870LCR-5G

	7.1 m BE-boom		8.4 m R-boom
Arm length	2.95 m BER-arm	3.7 m R-arm	3.7 m R-arm
Bucket digging force* ISO	472 kN (48 200 kgf)	402 kN (41 000 kgf)	402 kN (41 000 kgf)
Bucket digging force* SAE : PCSA	411 kN (41 900 kgf)	359 kN (36 600 kgf)	359 kN (36 600 kgf)
Arm crowd force* ISO	394 kN (40 200 kgf)	324 kN (33 100 kgf)	324 kN (33 100 kgf)
Arm crowd force* SAE : PCSA	378 kN (38 600 kgf)	316 kN (32 200 kgf)	316 kN (32 200 kgf)

\* At power boost



# SPECIFICATIONS

## DIMENSIONS

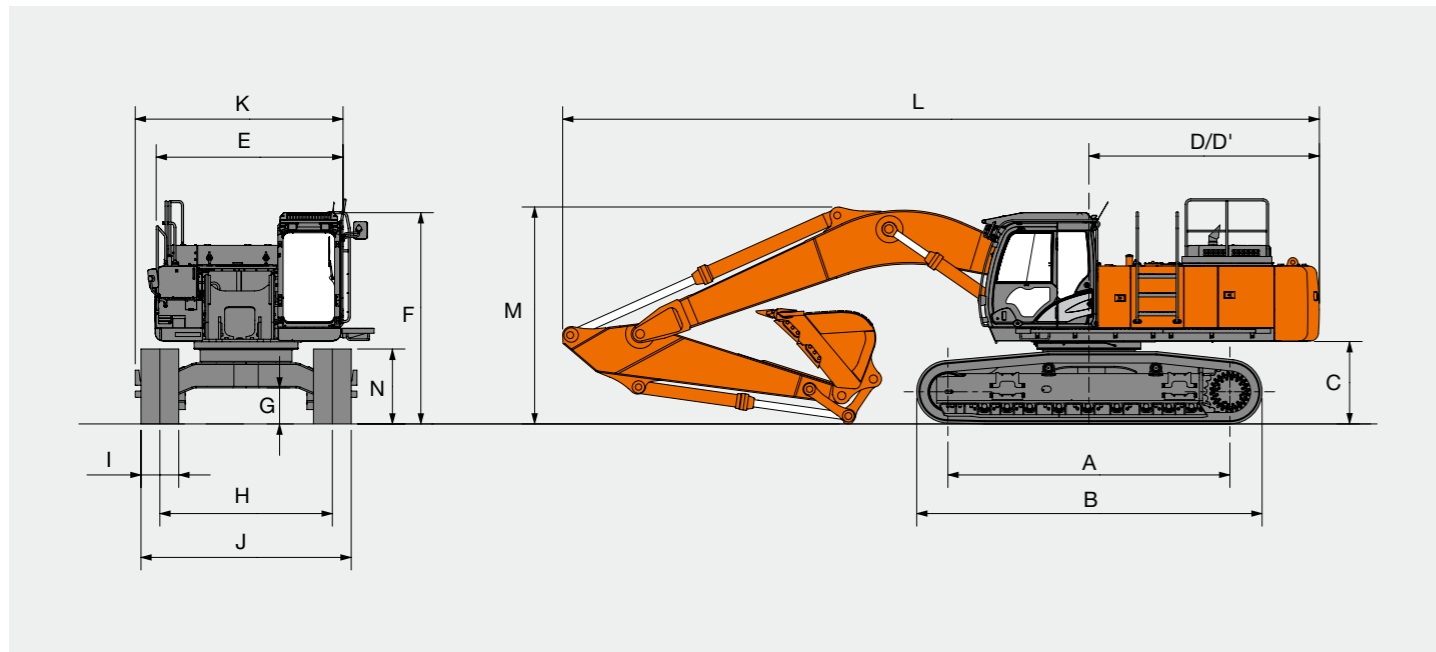

The illustration is shown ZX470LCR-5G

Unit: mm

Retractable gauge	ZX470R-5G	ZX470LCR-5G	ZX670LCR-5G	ZX870LCR-5G
A Distance between tumbler	4 040	4 470	4 590	5 110
B Undercarriage length	5 040	5 470	5 840	6 360
*1 C Counterweight clearance	1 230	1 270	1 530	1 680
D Rear-end swing radius	3 670	3 670	4 020	4 600
D' Rear-end length	3 660	3 660	3 910	4 520
E Overall width upperstructure	3 480	3 480	4 090	4 120
F Overall height of cab	3 280	3 320	3 660	3 800
*1 G Min. ground clearance	495	535	860	890
H Track gauge: Extended / Retracted	2 740	2 740	3 300 / 2 830	3 450 / 2 830
I Track shoe width	600	600	650	650
J Undercarriage width with 600 mm shoe	3 340	3 340	-	-
: Extended / Retracted with 650 mm shoe	-	-	3 950 / 3 480	4 100 / 3 480
K Overall width	3 820	3 820	4 360	4 450
L Overall length	12 040	12 040	13 400	14 800
M Overall height of boom	3 740	4 120	4 460	4 770
N Track height	1 150	1 150	1 440	1 500

\*1 Excluding track shoe lug

## WORKING RANGES

### ZX470R-5G / ZX470LCR-5G

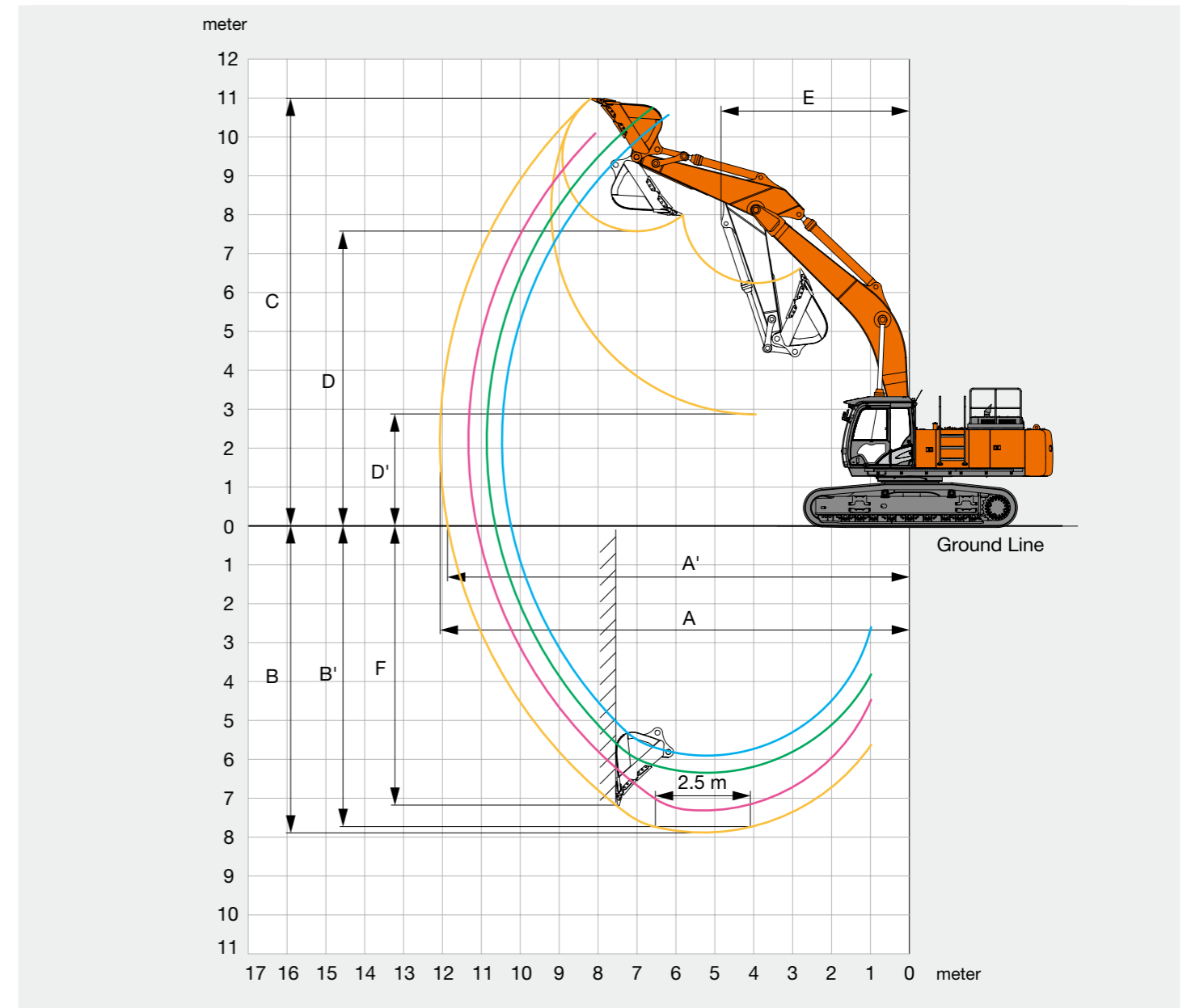

Unit: mm

	ZX470R-5G		ZX470LCR-5G			
	7.0 m R-boom		6.3 m BER-boom		7.0 m R-boom	
	2.9 m BER-arm	3.4 m R-arm	2.5 m BER-arm	2.9 m BER-arm	2.9 m BER-arm	3.4 m R-arm
A Max. digging reach	11 330	12 060	10 460	10 750	11 330	12 060
A' Max. digging reach (on ground)	11 120	11 860	10 230	10 630	11 110	11 860
B Max. digging depth	7 330	7 900	5 880	6 220	7 290	7 860
B' Max. digging depth (for 2.5 m level)	7 130	7 760	5 710	6 060	7 090	7 720
C Max. cutting height	10 040	10 920	10 570	10 700	10 080	10 980
D Max. dumping height	6 970	7 520	7 230	7 350	7 010	7 560
D' Min. dumping height	3 390	2 810	3 580	3 160	3 430	2 850
E Min. swing radius	5 020	4 840	4 090	3 930	5 020	4 840
F Max. vertical wall	4 400	7 230	4 350	4 740	4 360	7 190

Excluding track shoe lug

# SPECIFICATIONS

## WORKING RANGES

### ZX670LCR-5G

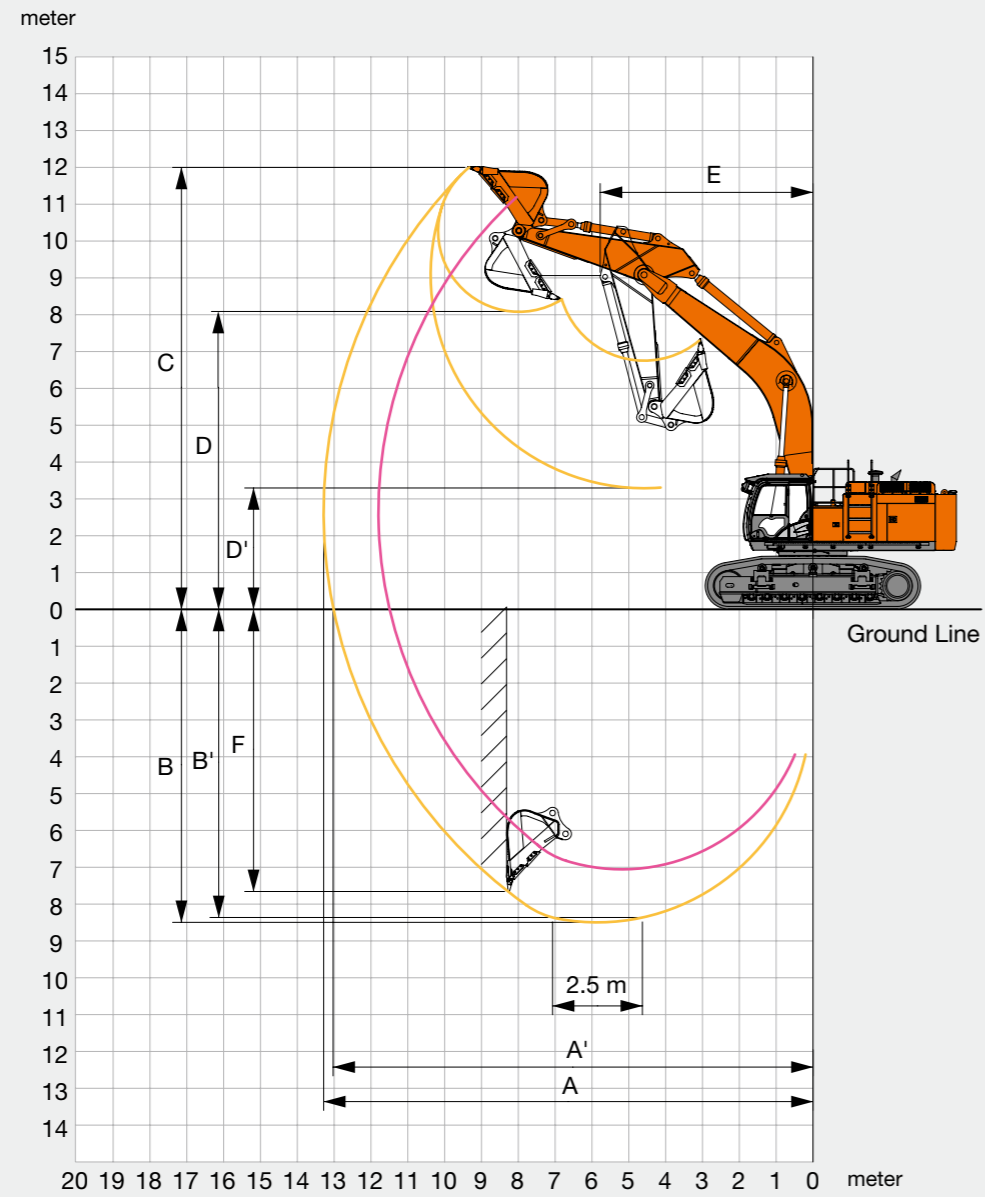

Unit: mm

	ZX670LCR-5G	
	6.8 m BER-boom	7.8 m R-boom
	2.9 m BER-arm	3.6 m R-arm
A Max. digging reach	11 800	13 280
A' Max. digging reach (on ground)	11 500	13 030
B Max. digging depth	7 120	8 560
B' Max. digging depth (for 2.5 m level)	6 970	8 420
C Max. cutting height	11 190	11 940
D Max. dumping height	7 330	8 020
D' Min. dumping height	3 200	3 230
E Min. swing radius	5 240	5 780
F Max. vertical wall	5 280	7 720

Excluding track shoe lug

## WORKING RANGES

### ZX870LCR-5G

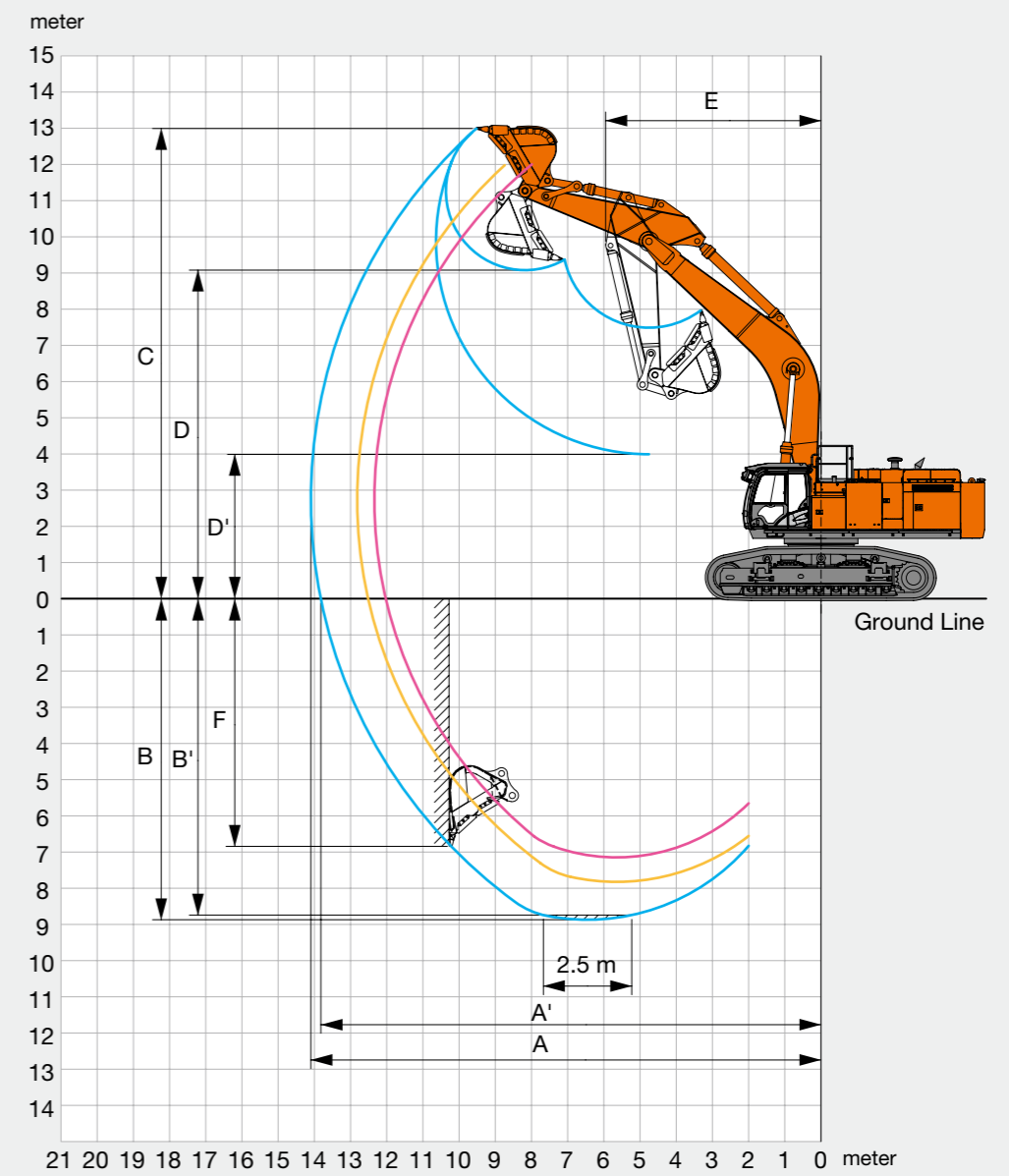

Unit: mm

	ZX870LCR-5G		
	7.1 m BER-boom		8.4 m R-boom
	2.95 m BER-arm	3.7 m R-arm	3.7 m R-arm
A Max. digging reach	12 340	12 820	14 100
A' Max. digging reach (on ground)	12 020	12 510	13 820
B Max. digging depth	7 140	7 820	8 870
B' Max. digging depth (for 2.5 m level)	7 000	7 690	8 740
C Max. cutting height	12 010	12 130	13 000
D Max. dumping height	8 130	8 180	9 080
D' Min. dumping height	3 770	3 000	3 990
E Min. swing radius	5 210	5 090	5 950
F Max. vertical wall	4 100	6 090	6 840

Excluding track shoe lug





## ZX670LCR-5G

### UPPERSTRUCTURE

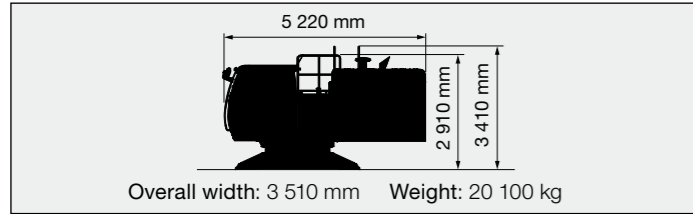

### COUNTERWEIGHT

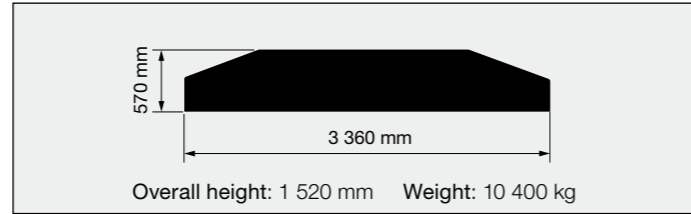

### BASIC MACHINE (WITHOUT COUNTERWEIGHT)

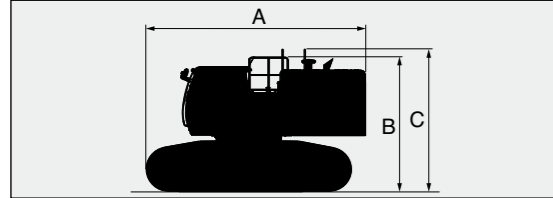

Shoe width	Overall width <sup>*1</sup>	Weight	A	B	C
650 mm	3 480 mm	43 700 kg	6 240 mm	3 820 mm	4 050 mm

<sup>\*1</sup> Undercarriage retracted

### SIDE FRAME

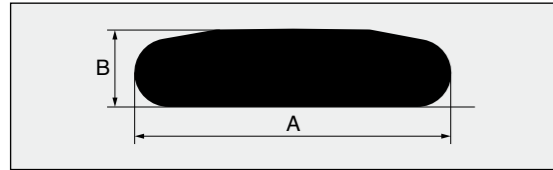

Shoe width	Overall width	Weight	A	B
650 mm	1 250 mm	10 800 kg	5 840 mm	1 450 mm

### BOOM

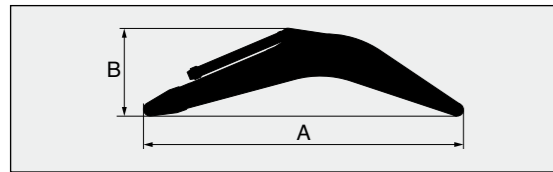

Boom	A	B	Overall width	Weight
6.8 m BER	7 140 mm	2 510 mm	1 390 mm	6 260 kg
7.8 m R	8 130 mm	2 330 mm	1 390 mm	6 760 kg

### ARM

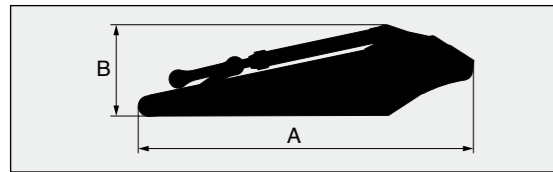

Arm	A	B	Overall width	Weight
2.9 m BER	4 370 mm	1 690 mm	800 mm	3 950 kg
3.6 m R	5 110 mm	1 440 mm	800 mm	3 900 kg

### BUCKET

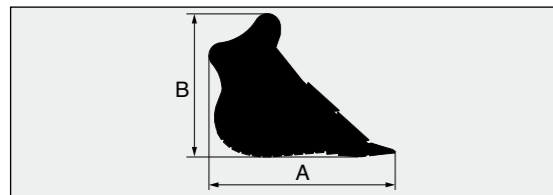

R-bucket

Bucket Capacity ISO heaped	A	B	Overall width	Weight
2.90 m <sup>3</sup>	2 290 mm	1 770 mm	1 680 mm	3 300 kg
3.30 m <sup>3</sup>	2 250 mm	1 890 mm	1 790 mm	3 610 kg

### BOOM CYLINDERS 550 kg X 2 Overall height: 410 mm

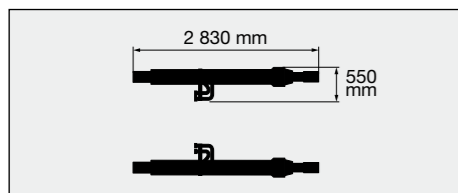

### HOSE OF BOOM CYLINDERS 7 kg X 2 / 10 kg X 2

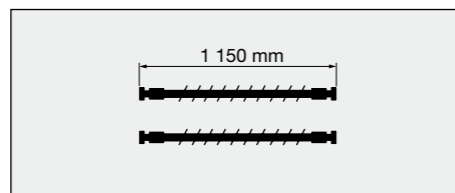

### LEFT SIDEWALK Overall height: 150 mm

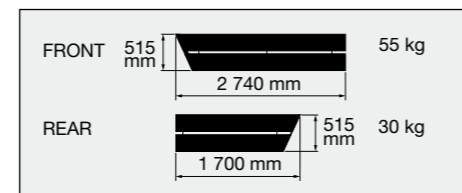

## ZX870LCR-5G

### UPPERSTRUCTURE

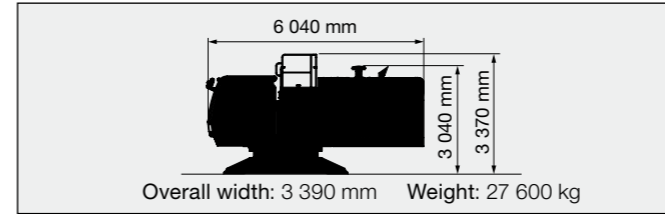

### COUNTERWEIGHT

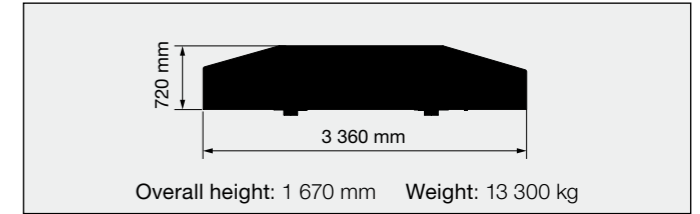

### BASIC MACHINE (WITHOUT COUNTERWEIGHT)

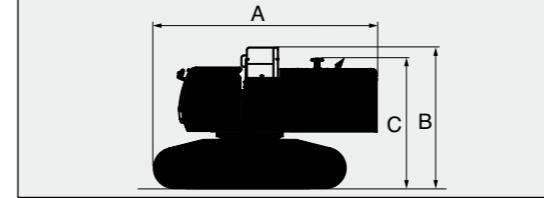

Shoe width	Overall width <sup>*1</sup>	Weight	A	B	C
650 mm	3 600 mm	52 600 kg	7 080 mm	4 300 mm	3 960 mm

<sup>\*1</sup> Undercarriage retracted

### SIDE FRAME

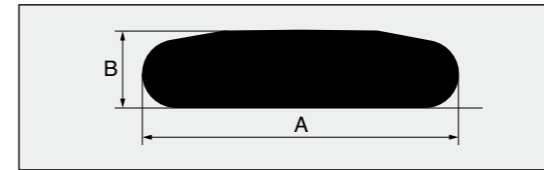

Shoe width	Overall width	Weight	A	B
650 mm	1 330 mm	12 700 kg	6 360 mm	1 500 mm

### BOOM

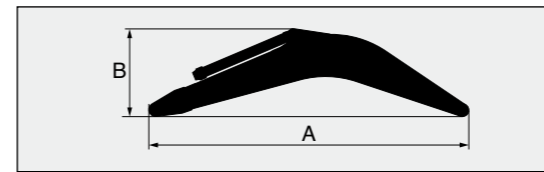

Boom	A	B	Overall width	Weight
7.1 m BER	7 490 mm	2 700 mm	1 450 mm	7 680 kg
8.4 m R	8 780 mm	2 500 mm	1 450 mm	8 270 kg

### ARM

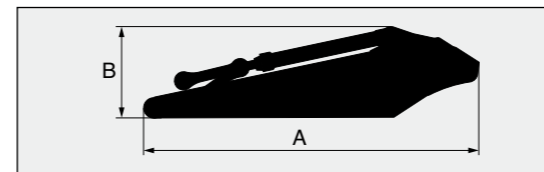

Arm	A	B	Overall width	Weight
2.95 m BER	4 460 mm	1 660 mm	850 mm	4 760 kg
3.7 m R	5 290 mm	1 420 mm	820 mm	4 610 kg

### BUCKET

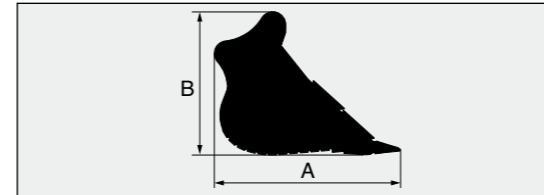

R-bucket

Bucket Capacity ISO heaped	A	B	Overall width	Weight
3.50 m <sup>3</sup>	2 240 mm	1 920 mm	1 890 mm	4 870 kg
3.70 m <sup>3</sup>	2 240 mm	1 920 mm	1 970 mm	4 970 kg
4.30 m <sup>3</sup>	2 310 mm	2 000 mm	2 110 mm	5 690 kg

### BOOM CYLINDERS 850 kg X 2 Overall height: 410 mm

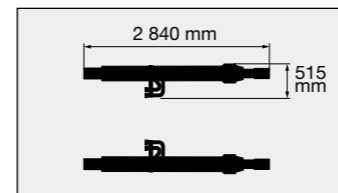

### HOSE OF BOOM CYLINDERS 9 kg X 2 / 13 kg X 2

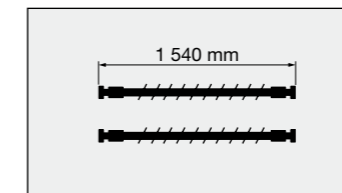

### LEFT SIDEWALK Overall height: 150 mm

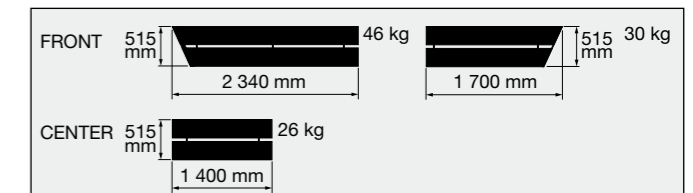

Standard and optional equipment may vary by country, so please consult your Hitachi dealer for details.

● : Standard equipment ○ : Optional equipment — : Not applicable

ENGINE	ZX470R-5G	ZX470LCR-5G	ZX670LCR-5G	ZX870LCR-5G
Auto idle system	●	●	●	●
Cartridge-type engine oil filter	●	●	●	●
Cartridge-type fuel filter	●	●	●	●
Dry-type air double filter with evacuator valve (with air filter restriction switch for monitor)	●	●	●	●
Fan guard	●	●	●	●
Fuel pre-filter	●	●	●	●
Power mood control [H/P (High Power) PWR(Power) ECO(Economy) ]	●	●	●	●
Isolation-mounted engine	●	●	●	●
Pre-cleaner	○	○	○	○
Radiator, oil cooler with dust protective net	●	●	●	●
Radiator reserve tank	●	●	●	●
50 A alternator	●	●	●	●

HYDRAULIC SYSTEM				
Accessories for breaker	○	○	○	○
Accessories for breaker & crusher	○	○	○	○
Accessories for 2 speed selector	○	○	○	○
Auto power lift	●	●	●	●
Boom mode selector system	●	●	●	●
Control valve with main relief valve	●	●	●	●
Drain filter	●	●	●	●
Engine speed sensing system	●	●	●	●
E-P control system	●	●	●	●
Extra port for control valve	●	●	●	●
Full-flow filter	●	●	●	●
Hose rupture valve	○	○	○	○
Pilot filter	●	●	●	●
Power boost	●	●	●	●
Quick warm-up system for pilot circuit	●	●	●	●
Shockless valve in pilot circuit	●	●	●	●
Suction filter	●	●	●	●
Work mode selector	●	●	●	●

CAB				
Additional fuse box	●	●	●	●
Adjustable armrests	●	●	●	●
All-weather sound suppressed steel cab	●	●	●	●
AM-FM radio	●	●	●	●
Ashtray	●	●	●	●
Auto control air conditioner	●	●	●	●
Auto-idle selector	●	●	●	●
AUX. terminal and storage	○	○	○	○
Cab: H/R cab	●	●	●	●
OPG top guard fitted Level II (ISO10262)	●	●	●	●
OPG front guard fitted Level II (ISO10262)	○	○	○	○
Laminated straight glass front window	●	●	●	●

	ZX470R-5G	ZX470LCR-5G	ZX670LCR-5G	ZX870LCR-5G
Left side window can be opened	●	●	●	●
Drink holder	●	●	●	●
Engine shut-off cable	●	●	●	●
Electric double horn	●	●	●	●
Evacuation hammer	●	●	●	●
Fire extinguisher bracket	○	○	○	○
Floor mat	●	●	●	●
Footrest	●	●	●	●
Front window washer	●	●	●	●
Glove compartment	●	●	●	●
Hot & cool box	●	●	●	●
Intermittent windshield wiper	●	●	●	●
Key cylinder light	●	●	●	●
LED room light with door courtesy	●	●	●	●
Pilot control shut-off lever	●	●	●	●
Rear tray	●	●	●	●
Retractable seat belt	●	●	●	●
Rubber radio antenna	●	●	●	●
Seat : Adjustable reclining mechanical suspension	●	●	●	●
Seat : Adjustable reclining mechanical suspension with heater	○	○	○	○
Seat : Adjustable reclining air suspension with heater	○	○	○	○
Short wrist control levers	●	●	●	●
Storage box	●	●	●	●
Sun visor (front)	○	○	○	○
Sun visor (side)	○	○	○	○
Transparent roof with slide curtain	●	●	●	●
2 speakers	●	●	●	●
6 fluid-filled elastic mounts	●	●	●	●
12 V power outlet	○	○	○	○
24 V cigarette lighter	●	●	●	●

MONITOR SYSTEM				
Alarm buzzers: overheat, engine oil pressure	●	●	●	●
Alarms: overheat, engine warning, engine oil pressure, alternator, minimum fuel level, air filter restriction, work mode, etc.	●	●	●	●
Display of meters: water temperature, hour, fuel rate, clock	●	●	●	●
Other displays: work mode, auto-idle, glow, operating conditions etc.	●	●	●	●

LIGHTS				
Additional working light (boom light side)	○	○	○	—
2 cab lights	●	●	●	●
2 working lights	●	●	—	—
3 working lights	—	—	●	—
4 cab lights	○	○	○	○
4 working lights	—	—	—	●

Standard and optional equipment may vary by country, so please consult your Hitachi dealer for details.

● : Standard equipment ○ : Optional equipment — : Not applicable

UPPER STRUCTURE	ZX470R-5G	ZX470LCR-5G	ZX670LCR-5G	ZX870LCR-5G
Electric fuel refilling pump with auto stop	○	○	○	○
Auto-grease lubricator (without bucket and link pins)	○	○	○	○
Electrical grease pump with hose-reel	○	○	○	○
Fuel level float	●	●	●	●
Hydraulic oil level gauge	●	●	●	●
Ladder	●	●	●	●
Rear view camera	○	○	○	○
Rear view mirror (right & left side)	●	●	●	●
Side walk (cab side)	●	●	●	●
Swing parking brake	●	●	●	●
Tool box	●	●	●	●
Utility space	●	●	●	●
170 Ah batteries	●	●	●	●
4.5 mm thickness undercover	●	●	●	●
9 080 kg counterweight	●	●	—	—
10 400 kg counterweight	—	—	●	—
13 300 kg counterweight	—	—	—	●

UNDERCARRIAGE				
Bolt-on sprocket	●	●	●	●
Full track guard	●	●	●	●
Hydraulic track adjuster	●	●	●	●
Reinforced track links with pin seals	●	●	●	●
Reinforced idler part	●	●	●	●
Reinforced travel motor covers	●	●	●	●
Travel parking brake	●	●	●	●
Track undercover	○	○	○	○
Upper and lower rollers	●	●	●	●
600 mm triple grouser shoes	●	●	—	—
600 mm double grouser shoes	○	○	—	—
650 mm double grouser shoes	—	—	●	●

FRONT ATTACHMENTS	ZX470R-5G	ZX470LCR-5G	ZX670LCR-5G	ZX870LCR-5G
Arm cylinder hose protectors	●	●	●	●
Boom cylinder hose protectors	●	●	●	●
Bucket cylinder hose protectors	●	●	●	●
Centralized lubrication system	●	●	●	●
Damage prevention plate and square bars	●	●	●	●
Dirt seal on all bucket pins	●	●	●	●
Flanged pin	●	●	●	●
Reinforced link A	●	●	●	●
Reinforced link B	●	●	●	●
1.9 m³ (ISO heaped) R-bucket (with dual type side shrouds)	●	●	—	—
7.0 m R-boom and 3.4 m R-arm	●	●	—	—
6.3 m BER-boom	○	○	—	—
2.5 m BER-arm	○	○	—	—
2.9 m BER-arm	○	○	—	—
2.9 m³ (ISO heaped) R-bucket (with dual type side shrouds)	—	—	●	—
7.8 m R-boom and 3.6 m R-arm	—	—	●	—
6.8 m BER-boom	—	—	○	—
2.9 m BER-arm	—	—	○	—
3.5 m³ (ISO heaped) R-bucket (with dual type side shrouds)	—	—	—	●
8.4 m R-boom and 3.7 m R-arm	—	—	—	●
7.1 m BER-boom	—	—	—	○
2.95 m BER-arm	—	—	—	○

MISCELLANEOUS				
Anti-slip steps and handrails	●	●	●	●
Lockable fuel refilling cap	●	●	●	●
Lockable machine covers	●	●	●	●
Onboard information controller	●	●	●	●
Standard tool kit	●	●	●	●
Theft deterrent system	●	●	●	●
Travel direction mark on track frame	●	●	●	●

OTHERS				
Global e-Service	●	●	●	●



**Built on the foundation of superb technological capabilities, Hitachi Construction Machinery is committed to providing leading-edge solutions and services to contribute as a reliable partner to the business of customers worldwide.**

## Hitachi Environmental Vision 2025

The Hitachi Group released the Environmental Vision 2025 to curb annual carbon dioxide emissions. The Group is committed to global production while reducing environmental impact in life cycles of all products, and realizing a sustainable society by tackling three goals — prevention of global warming, conservation of resources, and preservation of ecosystem.

### Reducing Environmental Impact by New ZAXIS

Hitachi makes a green way to cut carbon emissions for global warming prevention according to LCA\*. New ZAXIS utilizes lots of technological advances, including the new ECO mode, and Isochronous Control. Hitachi has long been committed to recycling of components, such as aluminum parts in radiators and oil cooler. Resin parts are marked for recycling.

\*Life Cycle Assessment – ISO 14040

Before using a machine with a satellite communication system, please make sure that the satellite communication system complies with local regulations, safety standards and legal requirements. If not so, please make modifications accordingly.

These specifications are subject to change without notice. Illustrations and photos show the standard models, and may or may not include optional equipment, accessories, and all standard equipment with some differences in color and features. Before use, read and understand the Operator's Manual for proper operation.