

ZAXIS-5 series

**HITACHI**

Reliable solutions

# ZAXIS 210W



## WHEEL EXCAVATOR

Model Code : ZX210W-5A

Engine Rated Power : 113 kW (152 HP)

Operating Weight : 20 100 - 21 600 kg

Backhoe Bucket : ISO Heaped : 0.80 - 0.91 m<sup>3</sup>







# ZAXIS Empower your Vision.

New ZAXIS provides reliable solutions: impressive fuel economy, swift front movements, and easy operation. You'll also find Hitachi technological prowess and expertise, such as the optimized hydraulic system and engine. New ZAXIS features the key benefits of high quality, low fuel consumption, and high durability, all of which serve to ensure low running costs. New ZAXIS, which is empowered by comprehensive evolution, will realize customers' visions and dreams, and pioneer your colorful future.

## CONTENTS

04

### More Production with Less Fuel

- More Improvements in Fuel Consumption (P to PWR)
- Increased Lifting Capacity
- Power Boost



06

### High Quality and Durability

- Enhanced Engine Reliability and Durability
- Durable Design
- Improved Durability of Front Attachment



08

### No Compromise on Operator Comfort

- Open Footwell
- Comfortable Operating Environment
- Comfort-Designed Operator Seat
- Large, Easy-to-Use Multifunctional Screen



10

### Focused on Safety

- The Large, Multifunctional Color LCD Monitor Does Not Obscure Visibility
- Improved Visibility and Ease of Entry



12

### Simplified Maintenance

- Dust-Proof Indoor Net for Cooling System
- The Multifunctional Monitor Helps During Maintenance
- Bottom Cover for Fuel Tank Cleaning



14

### Support Chain

- Remote Fleet Management with Global e-Service
- Parts and Service



16

### ConSite

- Automatic Data Report Service



# More Production with **Less Fuel**

## Achieving Low Fuel Consumption and a Large Workload

The HIOS III hydraulic system, which is an operator friendly HIOS III hydraulic system combined with efficient hydraulic control, was selected. It includes an hydraulic boosting system and an enhanced boom recirculation system to increase operating speed and reduce fuel consumption.

**More Improvements in Fuel Consumption (P to PWR) -14%**

**Increased Lifting Capacity +6%**

### Power Boost

When more digging force is needed, pressing the right button on the control lever will increase digging force by 10% for up to eight seconds.

**Hydraulic:**  
4.5 m at height 3 m

**ZX210W-5A**  
**6%**

**Tipping load:**  
6.0 m at ground level

**Same as**  
**ZX-W-3**

### Power Boost

			ZX210W-5A		Conventional ZX210W-3	
			Normal	Power Boost	Normal	Power Boost
Digging Force	Bucket	kN	143	158	143	151
	Arm	kN	103	114	103	109









HITACHI



# High Quality and Durability

## Enhanced Engine Reliability and Durability

The new engine, which is designed for use in harsh operating environment, is highly durable thanks to a fundamental review of the fuel and cooling systems.



## Durable Design



### Blade Cylinder Full Cover

The cover to protect the blade cylinder is larger. There is also a structure that conforms to the top and bottom of the blade to protect the blade cylinder.



### Reinforced Outrigger Cylinder Cover

The cover is reinforced to protect cylinder against damage.

### Strong D-section Skirt

The upper structure frame is reinforced with the D-section skirt increase rigidity against damage by obstacles.



### D-section skirt

### Improved Durability of Front Attachment

The boom top and foot are reinforced with thickened high-tensile steel brackets, which incorporate steel bushings to enhance durability. The arm-bucket joint is protected by WC thermal spraying on its contact surfaces to reduce wear and jolt. The HN bushings, utilized on joint pins, retain grease inside for longer greasing intervals.



### Cross-section

## Pre-cleaner for Extending Filter Life

The pre-cleaner is used in dusty environments. Collected dust is discharged automatically, reducing the frequency of filter cleaning and extending filter life.

 : option



### Pre-cleaner



# No Compromise on Operator Comfort

## Open Footwell

Open footwell under the monitor.  
The seat will also slide a long distance providing a comfortable operation environment compared to ZX-3.

- 1 Seat slide range lengthened by 30 mm  
Backwards: total slide length is 350 mm
- 2 Console slide range lengthened by 40 mm forwards
- 3 Legroom widened by 45 mm



## Comfortable Operating Environment

You'll feel comfortable and confident, with plenty of leg space and excellent visibility when operating in the cab. The new compact console gives more leg space. The new door pillar is shifted rearward by 70 mm to widen an entry space for easy access. A new LED room light, interlocked with the door, turns on when the door opens. The front window is easily removed and stored overhead using slide rails. The overhead window is openable for ventilation. Ample air conditioner vents are located strategically for uniform air circulation inside the cab. The control panel and control levers are arranged within easy reach of the operator. AM/FM radio and AUX port (optional) for a mobile music player are available for a long work day with less fatigue. All these designs focus on operator comfort.



## Comfort-Designed Operator Seat

The luxury cloth seat is fitted with a headrest and arm rests for operator comfort. The seat can be adjusted in multiple ways, sliding and reclining, to suit operator's size and preferences. The seat can slide rearward by 40 mm more for added leg space.







## Large, Easy-to-Use Multifunctional Screen

### Machine Conditions and Settings All Displayed on the Multifunctional Monitor

The new multi-language, multifunction monitoring system comprises a 7-inch high-resolution color monitor and a multifunctional controller. The monitor allows the operator to check varying operating variables: hydraulic oil temperature, fuel level, work mode, full-auto air conditioner, AM/FM radio, rear view.



Menu Items																																								
<table border="1"> <tr><td colspan="2">Main Menu</td></tr> <tr><td colspan="2">1 / 6</td></tr> <tr><td>Alarm List</td><td></td></tr> <tr><td>Air Conditioner</td><td></td></tr> <tr><td>Radio</td><td></td></tr> <tr><td>Work Mode</td><td></td></tr> <tr><td>Setting Menu</td><td></td></tr> </table>	Main Menu		1 / 6		Alarm List		Air Conditioner		Radio		Work Mode		Setting Menu		<table border="1"> <tr><td colspan="2">Work Mode</td></tr> <tr><td colspan="2">1 / 5</td></tr> <tr><td>Bucket</td><td></td></tr> <tr><td>Breaker 1</td><td></td></tr> <tr><td>Pulverizer 1</td><td></td></tr> <tr><td>Crusher 1</td><td></td></tr> <tr><td>Grapple 1</td><td></td></tr> </table>	Work Mode		1 / 5		Bucket		Breaker 1		Pulverizer 1		Crusher 1		Grapple 1		<table border="1"> <tr><td colspan="2">Engine Oil</td></tr> <tr><td colspan="2">Previous Maintenance</td></tr> <tr><td>2000/01/01</td><td>0.0h</td></tr> <tr><td>Remains</td><td>496.1h</td></tr> <tr><td>Maintenance Interval</td><td>500.0h</td></tr> </table>	Engine Oil		Previous Maintenance		2000/01/01	0.0h	Remains	496.1h	Maintenance Interval	500.0h
Main Menu																																								
1 / 6																																								
Alarm List																																								
Air Conditioner																																								
Radio																																								
Work Mode																																								
Setting Menu																																								
Work Mode																																								
1 / 5																																								
Bucket																																								
Breaker 1																																								
Pulverizer 1																																								
Crusher 1																																								
Grapple 1																																								
Engine Oil																																								
Previous Maintenance																																								
2000/01/01	0.0h																																							
Remains	496.1h																																							
Maintenance Interval	500.0h																																							

Main menu

Work mode menu

Engine oil



# Focused on **Safety**



## The Large, Multifunctional Color LCD Monitor Does Not Obscure Visibility

Color monitor has the same size as the pillar in the right front portion of the cab, so as not to block the operator's view.



## Rear View Monitor with Improved Visibility

ZX-5's rear view camera has a broadened visual range, so that the operator can see the area right below the counterweight. Moreover, it is possible to view both the operation status icons and the rear view monitor display simultaneously, without the hassle of having to switch between displays.



## Improved Visibility and Ease of Entry

Left-side visibility and ease of entry are improved by moving the door pillar to the back.



## Side-View Monitor Camera

The side-view camera and monitor are provided as optional equipment for safer operation in confined jobsites.



Camera



Monitor

 : option



# Simplified Maintenance



## Dust-Proof Indoor Net for Cooling System

In the new ZAXIS-5A, the dust-proof indoor net has been placed at the external side of the air conditioner condenser and fuel cooler.

In addition, since the dust-proof indoor net has been moved away from the fan in the new ZAXIS-5A, dust and particles can be evenly caught without gathering them in a single location.

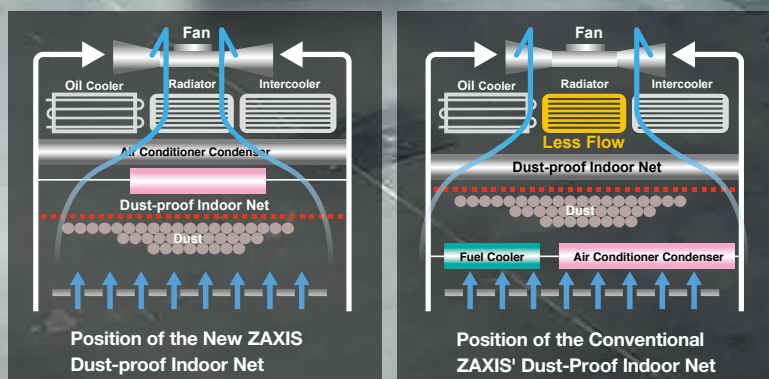

## The Multifunctional Monitor Helps during Maintenance

Each time the key switch is turned, the multifunctional monitor indicates the replacement timing of hydraulic oil and the fuel filters, according to the schedule, preset by the user. Scheduled maintenance helps to prevent the machine from breaking down.



## Bottom Cover for Fuel Tank Cleaning

The fuel tank is equipped with a bottom cover, allowing for easy cleaning of the inside of the tank.

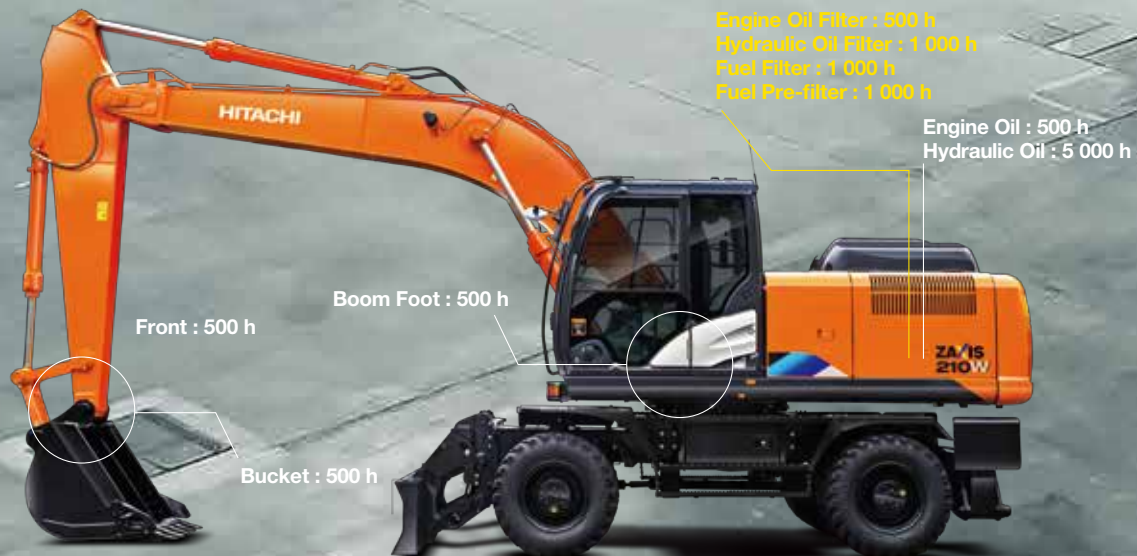



**Support Chain is a full customer support system offered after buying a Hitachi machine.**

## Remote Fleet Management with Global e-Service

### Easy Access to On-Site Machines through the Internet

This on-line fleet management system allows you to access each on-site machine from a PC in your office. You can get its operating information and location to increase productivity of the fleet and reduce downtime. Operating data and log are sent to a Hitachi server for processing, and then to customer and dealers around the world. This system is available 24 hours a day, all the year around.

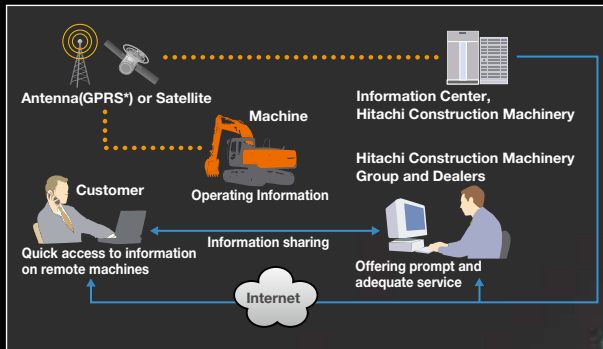

Note: In some regions, Global e-Service is not available by local regulations.  
\*General packet radio service

### Main Features of Global e-Service

#### Functions

Global e-Service provides easy access to a machine on site, conveying operating information and log, including daily operating hours, fuel level, temperatures, pressures, and likes.

#### Maintenance

Maintenance data and log are displayed on a easy-to-read monitor screen, suggesting recommended maintenance for efficient fleet management.



Operation



Maintenance



Location

## Parts and Service

**Hitachi full customer support is available every area on the globe for full customer satisfaction through Hitachi local dealers.**

### Parts

Hitachi Global Online Network, a parts supply system, is linked with Japan Parts Center, overseas depots and over 150 dealers abroad to deliver on-line parts information, including in-stock parts, order receptions, shipments and delivery period of over one million parts and components.

#### Genuine Hitachi Parts

Genuine Hitachi parts, meeting Hitachi stringent quality standards, are guaranteed according to Hitachi warranty standards. The use of genuine Hitachi parts, including engine, fuel, hydraulic oil and filters, may slash running costs, and extend machine life.

#### Ground Engaging Tools (GET)

Hitachi provides an array of Hitachi Ground Engaging Tools developed and built for a variety of applications. Using high-quality, well-maintained GET will help you get customers' trust.

Note: Some dealers do not handle Hitachi GET.

#### Remanufactured Components

Hitachi components are remanufactured according to the stringent remanufacturing standards at factories around the world. They have high quality equivalent to new ones, and backed up by Hitachi warranty system.

Note: Some dealers do not handle Hitachi Remanufactured Components.

### Service

#### Extended Warranty – HELP

Hitachi Standard Warranty System is available on all new Hitachi machines. In addition, Hitachi offers Hitachi Extended Life Programs (HELP) to suit customer expectations – protecting machines under tough operating conditions, avoiding unexpected downtime, and reducing repair costs.

Note: Warranty conditions vary by equipment.

#### Diagnostic Tools – Maintenance Pro

Electronic control system needs quick on-site solutions, apart from mechanical repairs. Hitachi's Maintenance Pro can diagnose machine failures in a short time by plugging a PC into a failed machine.

#### Technical Training

On-site servicing matters despite locations to keep the machine at peak performance and reduce downtime. Technical Training Center (TTC), located in Japan, educates and trains service technicians and service support personnel coming from Hitachi dealers and factories on the globe according to the international training programs.





# ConSite

ConSite is an automatic Data Report Service that sends a monthly e-mail summarising the information from Global e-Service for each of your Hitachi machines.

Available in more than 30 languages, ConSite includes a detailed analysis of the operational data, ratios and hours. This Monthly Report is also stored on the Owner's Site for ease of reference.

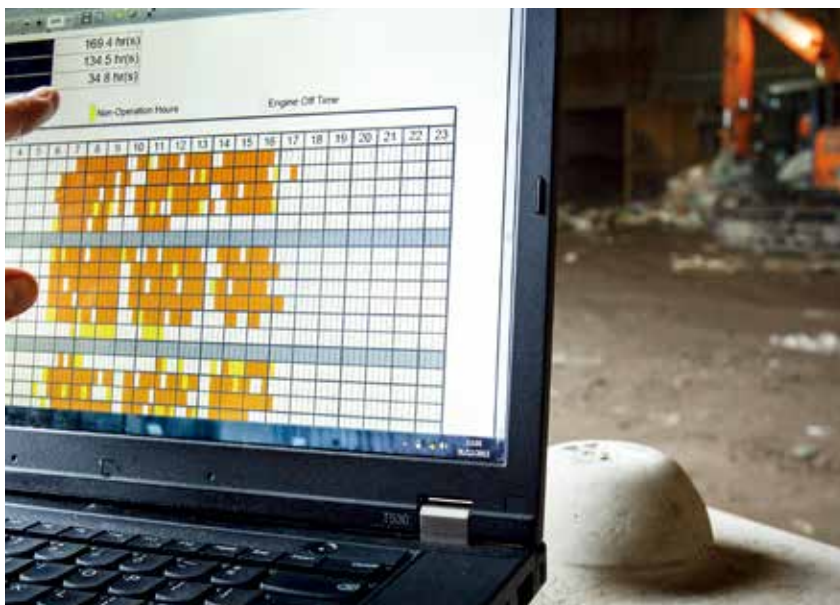

# A remote fleet monitoring system to improve overall performance

## ConSite

Our ConSite Data Report Service sends you a monthly e-mail to summarise the information available on Global e-Service for each of your Hitachi machines. It includes a detailed analysis of operational data, ratios and hours, so you can see how productive and efficient your machines have been in the past month. All the information from the report is stored in the Owner's Site as well, for easy reference.

Further into the ConSite Report, you'll see non-operation and swing efficiency ratings and ratios. These compare the machine's performance against the same model class from all Hitachi owners in your region.

The monthly and total number of hours are divided for front, swing, travel and attachment operations. This will help you to determine the actual usage of your machine and maintenance planning.

The monthly analysis of these variables is compared to the total lifetime of the machine in a user-friendly chart. A line graph shows the actual and projected number of hours, which helps you to manage maintenance requirements.

ConSite can also help you in the unlikely event of a fault. It will send you and your authorised Hitachi dealer an Emergency Alarm Report, so you can both respond quickly in order to minimise unscheduled downtime.

We created ConSite to improve your business operations, and enable you to analyze the productivity and efficiency of your equipment. The information it provides on machine usage is intended to help you with maintenance planning and also promotes proactive support from your dealer. Ultimately, it provides you with confidence in your Hitachi construction equipment and peace of mind to focus on other areas of your business.

## Owner's Site

You can find out all you need to know about your fleet of Hitachi construction machinery in the field from the comfort of your home or office, thanks to Owner's Site. This online management tool, available at [www.globaleservice.com](http://www.globaleservice.com), is user-friendly and offers extensive and detailed information on your Hitachi Zaxis Excavators and ZW Wheel Loaders.

The data is displayed in a flexible layout, so you can create machine groups per job site or select relevant information, depending on your requirements. As every project is different, you can customize the Owner's Site Dashboard to view data quickly and easily.



## Key Features

---

Check each of your machines from your office – 24/7

---

Have a remote insight into fuel consumption

---

Check the current and previous locations and movements of your machine(s)

---

See maintenance status and items due for renewal on each of your machines

---

Receive e-mail notifications for any machine alerts, unexpected movements and so on



# SPECIFICATIONS

## ENGINE

Model .....	Isuzu GI-4HK1X
Type .....	4-cycle water-cooled, direct injection
Aspiration .....	Turbocharged, intercooled
No. of cylinders .....	4
Rated power	
ISO 14396 .....	120 kW (161 HP) at 2 000 min <sup>-1</sup> (rpm)
ISO 9249, net .....	113 kW (152 HP) at 2 000 min <sup>-1</sup> (rpm)
SAE J1349, net .....	113 kW (152 HP) at 2 000 min <sup>-1</sup> (rpm)
Maximum torque .....	638 Nm (65 kgfm) at 1 500 min <sup>-1</sup> (rpm)
Piston displacement ..	5.193 L
Bore and stroke .....	115 mm x 125 mm
Batteries .....	2 x 12 V / 88 Ah

## HYDRAULIC SYSTEM

### Hydraulic Pumps

Main pumps .....	2 variable displacement axial piston pumps
Maximum oil flow ..	2 x 218 L / min
Pilot pump .....	1 gear pump
Maximum oil flow ..	51.4 L / min
Steering pump .....	1 gear pump
Maximum oil flow ..	30 L / min

### Hydraulic Motors

Travel .....	1 variable displacement axial piston motors
Swing .....	1 axial piston motor

### Relief Valve Settings

Implement circuit .....	34.3 MPa (350 kgf / cm <sup>2</sup> )
Swing circuit .....	30.2 MPa (308 kgf / cm <sup>2</sup> )
Travel circuit .....	35.3 MPa (360 kgf / cm <sup>2</sup> )
Pilot circuit .....	3.9 MPa (40 kgf / cm <sup>2</sup> )
Power boost .....	38.0 MPa (388 kgf / cm <sup>2</sup> )

### Hydraulic Cylinders

	Quantity	Bore	Rod diameter
Boom	2	120 mm	85 mm
Arm	1	135 mm	95 mm
Bucket	1	115 mm	80 mm

## UPPERSTRUCTURE

### Revolving Frame

D-section frame for resistance to deformation.

### Swing Device

Axial piston motor with planetary reduction gear is bathed in oil. Swing circle is single-row. Swing parking brake is spring-set/hydraulic-released disc type.

Swing speed .....	12.2 min <sup>-1</sup> (rpm)
Swing torque .....	61.5 kNm (6 270 kgfm)

### Operator's Cab

Independent spacious cab, 1 005 mm wide by 1 675 mm high, conforming to ISO\* Standards.

\* International Organization for Standardization

## UNDERCARRIAGE

Wheeled type undercarriage. The frame is of welded, stress-relieved structure.

Drive system: 2 speed power shift transmission and variable displacement axial piston type travel motor.

Travel speed (forward and reverse)

Creeper speed range .....	0 to 2.9 km / h
Low speed range .....	0 to 7.1 km / h
High speed range .....	0 to 27.5 km / h
Maximum traction force .....	118 kN (12 100 kgf)
Gradeability .....	70% (35 degree)
Min. turning radius .....	7 200 mm

Axle:

All-wheel drive.

The front axle can be locked hydraulically in any position.

Oscillating front axle .....

Brakes system:

Maintenance free wet-disc brakes on axle are standard.

Fully hydraulic service brake system.

## SERVICE REFILL CAPACITIES

Fuel tank .....	355.0 L
Engine coolant .....	31.0 L
Engine oil .....	23.0 L
Swing device .....	6.2 L
Transmission .....	2.5 L
Front differential gear .....	9.6 L
Rear differential gear .....	13.1 L
Hub reduction gear	
Front axle .....	2 x 2.5 L
Rear axle .....	2 x 2.5 L
Hydraulic system .....	340.0 L
Hydraulic oil tank .....	200.0 L

## WEIGHTS

### Operating Weight

Arm length	Stabilization	kg
2.42 m	Rear Blade	20 100
	Rear Outrigger	20 300
	Outrigger and Blade	21 300
	Front and Rear Outrigger	21 500
2.91 m	Rear Blade	20 100
	Rear Outrigger	20 400
	Outrigger and Blade	21 400
	Front and Rear Outrigger	21 600

Including 0.80 m<sup>3</sup> (ISO heaped), bucket weight (660 kg) and counterweight (3 850 kg).

## BUCKET AND ARM DIGGING FORCE

Arm length	ZAXIS 210W-5A	
	2.42 m	2.91 m
Bucket digging force* ISO	158 kN (16 100 kgf)	
Bucket digging force* SAE : PCSA	135 kN (13 800 kgf)	
Arm crowd force* ISO	140 kN (14 200 kgf)	114 kN (11 600 kgf)
Arm crowd force* SAE : PCSA	133 kN (13 600 kgf)	110 kN (11 200 kgf)

\* At power boost

## BACKHOE ATTACHMENTS

Boom and arms are of welded, box-section design. 2.42 m and 2.91 m arms are available. Bucket is of all-welded, high-strength steel structure.

### Buckets

Capacity		Width		No. of teeth	Weight	Recommendation	
SAE, PCSA heaped	CECE heaped	Without side cutters	With side cutters			2.42 m arm	2.91 m arm
0.80 m <sup>3</sup>	0.70 m <sup>3</sup>	1 030 mm	1 140 mm	5	670 kg	◎	◎
0.91 m <sup>3</sup>	0.80 m <sup>3</sup>	1 150 mm	1 280 mm	5	720 kg	◎	○

◎ Suitable for materials with density of 1 800 kg/m<sup>3</sup> or less

○ Suitable for materials with density of 1 600 kg/m<sup>3</sup> or less

□ Suitable for materials with density of 1 100 kg/m<sup>3</sup> or less



# SPECIFICATIONS

## DIMENSIONS

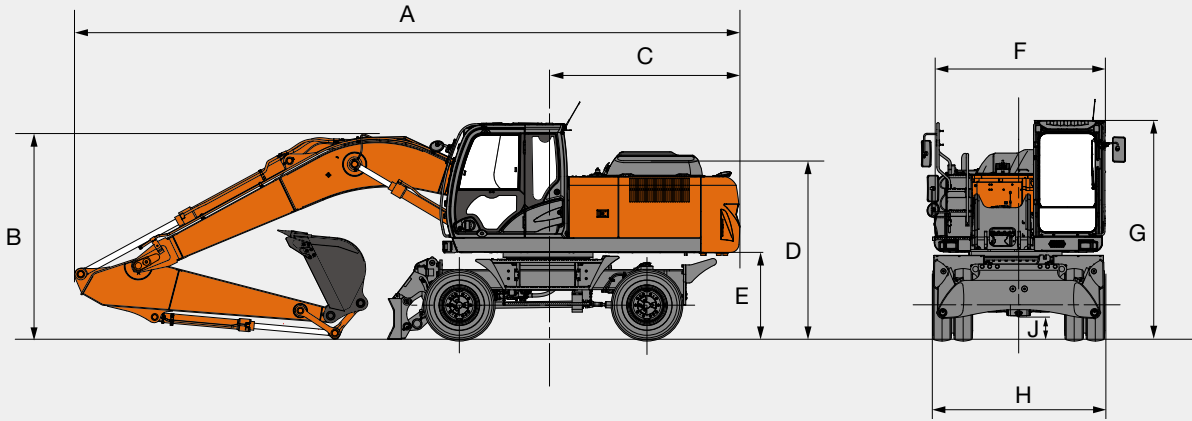

**FRONT BLADE AND REAR OUTRIGGER**

**FRONT AND REAR OUTRIGGER**

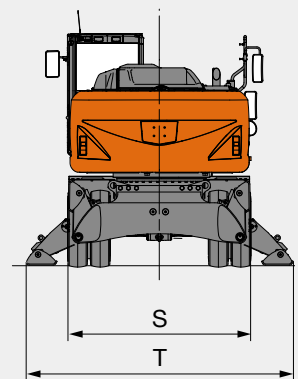
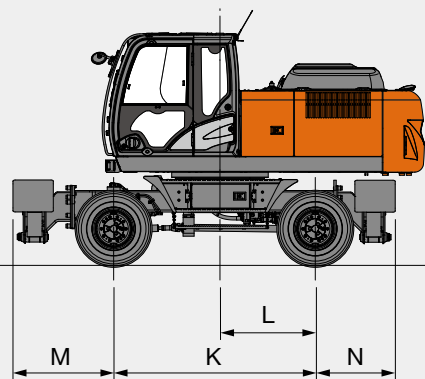
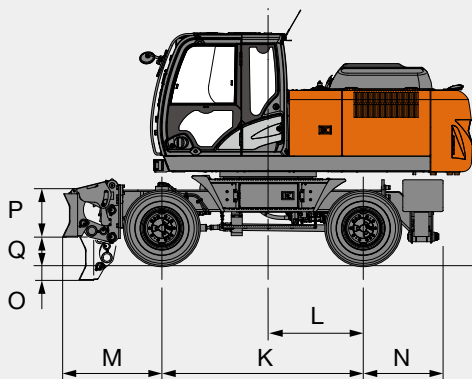

**REAR BLADE**

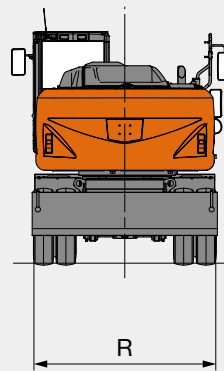
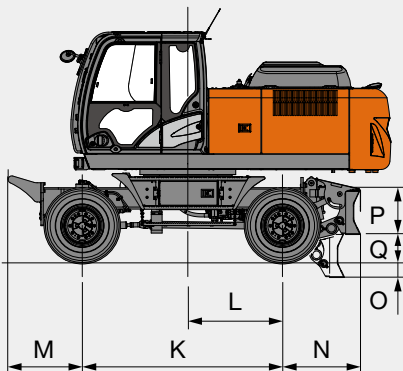

## DIMENSIONS

Unit : mm

		Rear BL	Rear O/R	Front BL Rear O/R	Front O/R Rear BL	Front and Rear O/R
A	Overall length (with monoblock boom)					
	2.42 m arm	9 880				
	2.91 m arm	9 750				
B	Overall length (with monoblock boom)					
	2.42 m arm	3 230				
	2.91 m arm	3 170* (2 990: Boom height)				
C	Rear-end swing radius	2 800				
D	Engine cover height	2 750				
E	Counterweight clearance	1 230				
F	Overall width of upper structure	2 470				
G	Overall height of cabin	3 170				
H	Overall width tires	2 530				
J	Min. ground clearance	325				
K	Wheel base	2 750				
L	Swing-centre to rear axle	1 300				
M	Front overhang	1 020		1 355	1 375	
N	Rear overhang	1 075	1 090		1 075	1 090
O	Max. blade lower	215	-	215		-
P	Height of blade	600	-	600		-
Q	Max. blade raise	375	-	375		-
R	Overall width of blade	2 530	-	2 530		-
S	Over width of O/R retract	-				2 470
T	Overall width O/R extend	-				3 440

Transportation dimensions are A, B, H.

\*Cabin Height.



# SPECIFICATIONS

## WORKING RANGES

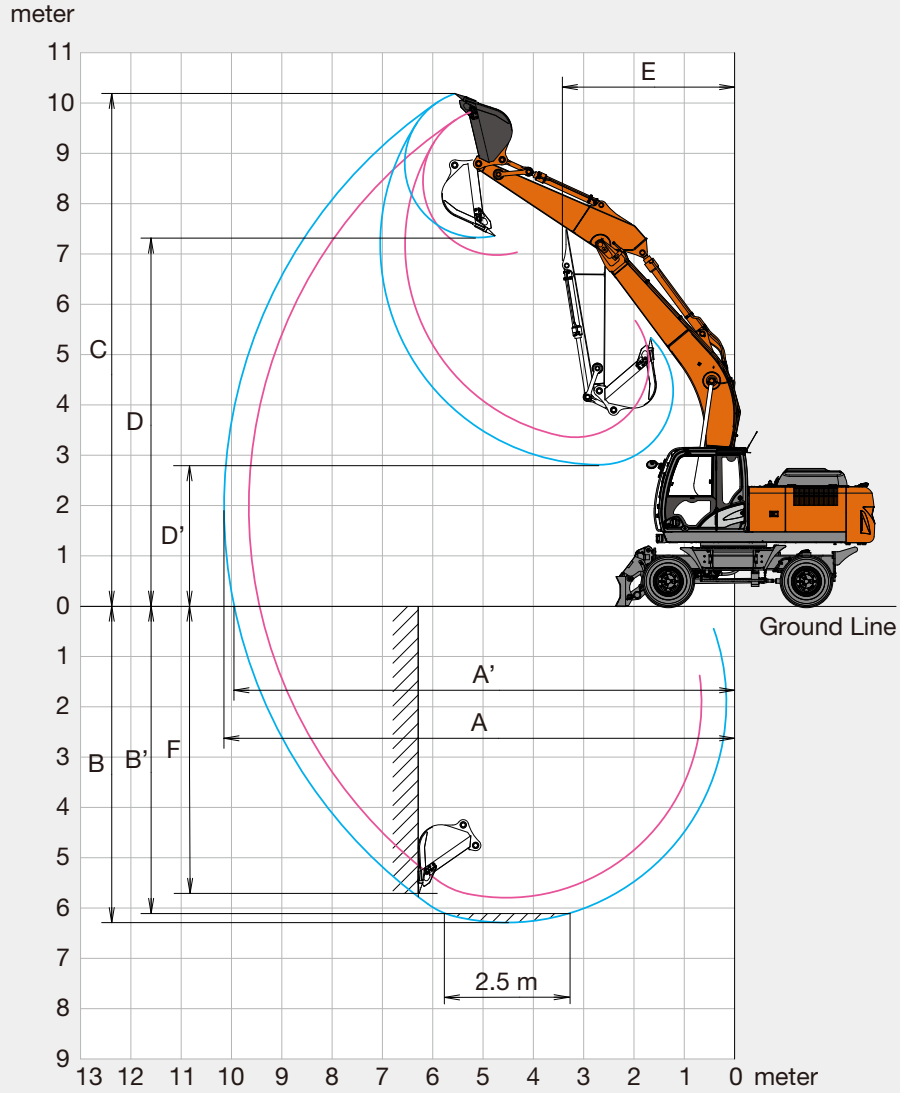

Unit: mm

	ZAXIS 210W-5A	
Arm length	2.42 m	2.91 m
A Max. digging reach	9 670	10 170
A' Max. digging reach (on ground)	9 460	9 960
B Max. digging depth	5 800	6 290
B' Max. digging depth (2.5 m level)	5 580	6 110
C Max. cutting height	9 840	10 190
D Max. dumping height	7 000	7 350
D' Min. dumping height	3 400	2 820
E Min. swing radius	3 520	3 430
F Max. vertical wall digging depth	5 130	5 600





# LIFTING CAPACITIES (Without Bucket)

## ZX210W-5A with 2.42 m ARM

### Metric measure

- Notes: 1. Ratings are based on ISO 10567.  
 2. Lifting capacity does not exceed 75% of tipping load with the machine on firm, level ground or 87% full hydraulic capacity.  
 3. The load point is the center-line of the bucket pivot mounting pin on the arm.  
 4. \*Indicates load limited by hydraulic capacity.  
 5. Each value with Rear blade up over the Front-axle side and each value with Rear blade down over the Rear-axle side respectively, and value in optimal position with positioning cylinder.  
 6. 0 m = Ground.  
 For lifting capacities, subtract bucket and quick hitch weight from lifting capacities without bucket.

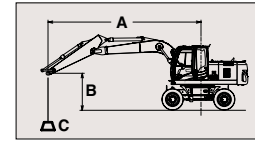

A: Load radius  
 B: Load point height  
 C: Lifting capacity

Rating over-front Rating over-side or 360 degrees Unit : kg

Stabilization		Load radius										At max. reach		
		1.5 m		3.0 m		4.5 m		6.0 m		7.5 m		meter		
7.5 m	Rear blade up													
	Rear blade down													
	Rear outrigger down													
	Front outrigger and rear blade down													
	Front blade and rear outrigger down 4 outrigger down													
6.0 m	Rear blade up							5 630	3 360			4 270	2 520	7.091
	Rear blade down							*5 820	3 790			*5 790	2 850	
	Rear outrigger down							*5 820	4 480			*5 790	3 380	
	Front outrigger and rear blade down							*5 820	5 750			*5 790	4 360	
	Front blade and rear outrigger down 4 outrigger down							*5 820	*5 820			*5 790	4 480	
4.5 m	Rear blade up					*7 850	4 880	5 440	3 190	3 840	2 230	3 610	2 090	7.787
	Rear blade down					*7 850	5 550	*6 460	3 620	*5 860	2 540	*5 830	2 380	
	Rear outrigger down					*7 850	6 630	*6 460	4 300	*5 860	3 030	5 550	2 840	
	Front outrigger and rear blade down					*7 850	*7 850	*6 460	5 560	*5 860	3 930	*5 830	3 690	
	Front blade and rear outrigger down 4 outrigger down					*7 850	*7 850	*6 460	5 720	*5 860	4 040	*5 830	3 800	
3.0 m	Rear blade up					7 890	4 340	5 180	2 960	3 730	2 140	3 300	1 870	8.137
	Rear blade down					*10 060	4 990	*7 390	3 390	*6 220	2 450	*5 950	2 150	
	Rear outrigger down					*10 060	6 040	*7 390	4 050	5 790	2 930	5 090	2 580	
	Front outrigger and rear blade down					*10 060	8 060	*7 390	5 300	*6 220	3 820	*5 950	3 380	
	Front blade and rear outrigger down 4 outrigger down					*10 060	8 330	*7 390	5 460	*6 220	3 930	5 660	3 470	
1.5 m	Rear blade up					7 440	3 960	4 950	2 760	3 630	2 040	3 200	1 790	8.187
	Rear blade down					*11 610	4 600	*8 230	3 180	*6 610	2 340	5 820	2 070	
	Rear outrigger down					*11 610	5 630	8 020	3 840	5 670	2 830	4 970	2 490	
	Front outrigger and rear blade down					*11 610	7 620	*8 230	5 070	*6 610	3 710	*6 120	3 280	
	Front blade and rear outrigger down 4 outrigger down					*11 610	7 880	*8 230	5 230	6 310	3 820	5 530	3 380	
0 m	Rear blade up					7 290	3 830	4 820	2 640	3 560	1 970	3 300	1 830	7.944
	Rear blade down					*11 940	4 460	*8 640	3 050	6 590	2 280	6 040	2 120	
	Rear outrigger down					*11 940	5 490	7 860	3 710	5 600	2 760	5 150	2 560	
	Front outrigger and rear blade down					*11 940	7 460	*8 640	4 940	*6 770	3 650	*6 330	3 380	
	Front blade and rear outrigger down 4 outrigger down					*11 940	7 720	*8 640	5 090	6 230	3 760	5 730	3 480	
-1.5 m	Rear blade up			*9 550	7 060	7 300	3 840	4 790	2 610			3 650	2 020	7.376
	Rear blade down			*9 550	8 380	*11 420	4 470	*8 460	3 030			*6 550	2 340	
	Rear outrigger down			*9 550	*9 550	*11 420	5 500	7 830	3 680			5 740	2 830	
	Front outrigger and rear blade down			*9 550	*9 550	*11 420	7 470	*8 460	4 910			*6 550	3 740	
	Front blade and rear outrigger down 4 outrigger down			*9 550	*9 550	*11 420	7 730	*8 460	5 070			6 390	3 850	
-3.0 m	Rear blade up			*13 630	7 240	7 430	3 950	4 890	2 700			4 500	2 510	6.392
	Rear blade down			*13 630	8 560	*10 020	4 590	*7 370	3 110			*6 690	2 890	
	Rear outrigger down			*13 630	10 820	*10 020	5 620	*7 370	3 770			*6 690	3 490	
	Front outrigger and rear blade down			*13 630	*13 630	*10 020	7 600	*7 370	5 000			*6 690	4 610	
	Front blade and rear outrigger down 4 outrigger down			*13 630	*13 630	*10 020	7 870	*7 370	5 160			*6 690	4 750	
-4.5 m	Rear blade up													
	Rear blade down													
	Rear outrigger down													
	Front outrigger and rear blade down													
	Front blade and rear outrigger down 4 outrigger down													

## ZX210W-5A with 2.91 m ARM

### Metric measure

- Notes: 1. Ratings are based on ISO 10567.  
 2. Lifting capacity does not exceed 75% of tipping load with the machine on firm, level ground or 87% full hydraulic capacity.  
 3. The load point is the center-line of the bucket pivot mounting pin on the arm.  
 4. \*Indicates load limited by hydraulic capacity.  
 5. Each value with Rear blade up over the Front-axle side and each value with Rear blade down over the Rear-axle side respectively, and value in optimal position with positioning cylinder.  
 6. 0 m = Ground.  
 For lifting capacities, subtract bucket and quick hitch weight from lifting capacities without bucket.

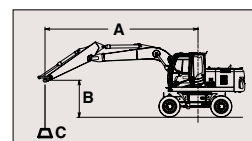

A: Load radius  
 B: Load point height  
 C: Lifting capacity

Rating over-front Rating over-side or 360 degrees Unit : kg

Stabilization		Load radius										At max. reach		meter
		1.5 m		3.0 m		4.5 m		6.0 m		7.5 m				
7.5 m	Rear blade up													
	Rear blade down													
	Rear outrigger down													
	Front outrigger and rear blade down													
	Front blade and rear outrigger down 4 outrigger down													
6.0 m	Rear blade up							*5 290	3 420	3 930	2 320	3 790	2 220	7.660
	Rear blade down							*5 290	3 860	*4 660	2 630	*4 030	2 530	
	Rear outrigger down							*5 290	4 540	*4 660	3 120	*4 030	3 000	
	Front outrigger and rear blade down							*5 290	*5 290	*4 660	4 020	*4 030	3 870	
	Front blade and rear outrigger down 4 outrigger down							*5 290	*5 290	*4 660	4 130	*4 030	3 980	
4.5 m	Rear blade up					*7 050	5 030	5 510	3 250	3 870	2 260	3 270	1 880	8.307
	Rear blade down					*7 050	5 700	*5 980	3 680	*5 480	2 570	*3 990	2 150	
	Rear outrigger down					*7 050	6 790	*5 980	4 360	*5 480	3 060	*3 990	2 570	
	Front outrigger and rear blade down					*7 050	*7 050	*5 980	5 620	*5 480	3 960	*3 990	3 350	
	Front blade and rear outrigger down 4 outrigger down					*7 050	*7 050	*5 980	5 780	*5 480	4 070	*3 990	3 440	
3.0 m	Rear blade up					8 060	4 480	5 240	3 010	3 750	2 150	3 010	1 700	8.634
	Rear blade down					*9 290	5 140	*6 990	3 430	*5 930	2 460	*4 120	1 950	
	Rear outrigger down					*9 290	6 200	*6 990	4 100	5 820	2 740	*4 120	2 350	
	Front outrigger and rear blade down					*9 290	8 230	*6 990	5 350	*5 930	3 840	*4 120	3 090	
	Front blade and rear outrigger down 4 outrigger down					*9 290	8 500	*6 990	5 510	*5 930	3 950	*4 120	3 180	
1.5 m	Rear blade up					7 540	4 030	4 980	2 780	3 630	2 030	2 930	1 630	8.682
	Rear blade down					*11 150	4 680	*7 940	3 200	*6 400	2 340	*4 420	1 880	
	Rear outrigger down					*11 150	5 720	*7 940	3 860	5 680	2 820	*4 420	2 270	
	Front outrigger and rear blade down					*11 150	7 710	*7 940	5 100	*6 400	3 710	*4 420	3 000	
	Front blade and rear outrigger down 4 outrigger down					*11 150	7 970	*7 940	5 260	6 310	3 820	*4 420	3 090	
0 m	Rear blade up			*4 210	*4 210	7 290	3 830	4 820	2 630	3 530	1 950	3 000	1 650	8.453
	Rear blade down			*4 210	*4 210	*11 890	4 460	*8 520	3 050	6 570	2 260	*4 960	1 910	
	Rear outrigger down			*4 210	*4 210	*11 890	5 490	7 860	3 700	5 570	2 740	4 680	2 320	
	Front outrigger and rear blade down			*4 210	*4 210	*11 890	7 470	*8 520	4 930	*6 700	3 620	*4 960	3 080	
	Front blade and rear outrigger down 4 outrigger down			*4 210	*4 210	*11 890	7 730	*8 520	5 090	6 210	3 730	*4 960	3 170	
-1.5 m	Rear blade up			*8 670	6 900	7 250	3 790	4 760	2 580	3 510	1 930	3 270	1 800	7.924
	Rear blade down			*8 670	8 210	*11 680	4 420	*8 550	2 990	6 540	2 230	*5 940	2 090	
	Rear outrigger down			*8 670	*8 670	*11 680	5 450	7 790	3 640	5 540	2 710	5 130	2 530	
	Front outrigger and rear blade down			*8 670	*8 670	*11 680	7 420	*8 550	4 870	*6 590	3 600	*5 940	3 350	
	Front blade and rear outrigger down 4 outrigger down			*8 670	*8 670	*11 680	7 680	*8 550	5 030	6 180	3 710	5 720	3 450	
-3.0 m	Rear blade up			*14 470	7 080	7 330	3 860	4 800	2 620			3 900	2 160	7.022
	Rear blade down			*14 470	8 390	*10 610	4 500	*7 840	3 030			*6 270	2 490	
	Rear outrigger down			*14 470	10 640	*10 610	5 530	*7 840	3 690			6 190	3 020	
	Front outrigger and rear blade down			*14 470	*14 470	*10 610	7 510	*7 840	4 920			*6 270	3 990	
	Front blade and rear outrigger down 4 outrigger down			*14 470	*14 470	*10 610	7 770	*7 840	5 070			*6 270	4 120	
-4.5 m	Rear blade up					7 580	4 070					5 580	3 100	5.555
	Rear blade down					*8 200	4 710					*6 230	3 560	
	Rear outrigger down					*8 200	5 750					*6 230	4 310	
	Front outrigger and rear blade down					*8 200	7 750					*6 230	5 710	
	Front blade and rear outrigger down 4 outrigger down					*8 200	8 020					*6 230	5 890	



# EQUIPMENT

Standard and optional equipment may vary by country, so please consult your Hitachi dealer for details.

● : Standard equipment ○ : Optional equipment

ENGINE	
Air cleaner double filters	●
Auto idle system	●
Cartridge-type engine oil filter	●
Cartridge-type fuel main filter	●
Cartridge-type fuel pre-filter with water separator	●
Cold fuel resistance valve	●
Dry-type air filter with evacuator valve (with air filter restriction indicator)	●
Dust-proof indoor net	●
ECO / PWR mode control	●
Electrical fuel feed pump	●
Engine oil drain coupler	●
Engine warm-up device	●
Fan guard	●
Fuel cooler	●
Isolation-mounted engine	●
Maintenance free pre-cleaner	○
Radiator expansion tank	●
Radiator, oil cooler and intercooler	●

HYDRAULIC SYSTEM	
Auto power lift	●
Control valve with main relief valve	●
Extra port for control valve	●
Full-flow filter	●
Hydraulic tank (with restriction indicator)	○
Pilot filter	●
Power boost	●
Steering filter	●
Suction filter	●
Swing dampener valve	●
Work mode selector	●

CAB	
All-weather sound suppressed steel cab	●
AM-FM radio	●
Ashtray	●
Auto control air conditioner	●
AUX. terminal and storage	○
CAB (Center pillar reinforced structure)	●
Drink holder with hot & cool function	●
Electric double horn	●
Engine shut-off switch	●
Evacuation hammer	●
Floor mat	●
Footrest	●
Front window washer	●
Hot & cool box	●
Intermittent windshield wipers	●
Key cylinder light	●
LED room light with door courtesy	●
Pilot control shut-off lever	●
Rain guard	○
Rear tray	●
Retractable seat belt	●
ROPS (ISO12117-2) compliant cab	○
Rubber radio antenna	●
Seat adjustment part : backrest, armrest, height and angle, slide forward / back	●
Seat : mechanical suspension seat	●
Short wrist control levers (Slim type)	●
Sun visor (front window)	○
Windows on front, upper, lower and left side can be openend	●
2 speakers	●
4 fluid-filled elastic mounts	●
12 V power outlet	○
24 V cigarette lighter	●

Standard and optional equipment may vary by country, so please consult your Hitachi dealer for details.

● : Standard equipment ○ : Optional equipment

<b>MONITOR SYSTEM</b>	
Alarm buzzers: overheat, engine oil pressure	●
Alarms: overheat, engine warning, engine oil pressure, alternator, minimum fuel level, hydraulic filter restriction, air filter restriction, work mode,etc	●
Display of meters: Speedometer, Tachometer, Trip meter, water temperature, hour, fuel rate, clock	●
Other displays: work mode, auto-idle, glow, rearview monitor, operating conditions, etc	●
32 languages selection	●

<b>LIGHTS</b>	
Additional boom light with cover	○
Additional cab roof front lights	○
Additional cab roof rear lights	○
Brake lamps	●
Clearance lamps	●
Hazard lamps	●
Licence lamp	○
Rotating lamp	○
Turn signal lamps	●
Working lights	●
2 head lights	●

<b>UPPER STRUCTURE</b>	
Batteries 2 x 88 Ah	●
Battery disconnect switch	●
Electric fuel refilling pump with auto stop and filter	○
Fuel level float	●
Hydraulic oil level gauge	●
Lockable fuel refilling cap	●
Lockable machine covers	●
Rear view camera	○
Rear view mirror (right & left side)	●
Side view camera	○
Skid-resistant plates and handrails	●
Swing parking brake	●
Undercover	●
3 800 kg counterweight	●

<b>UNDERCARRIAGE</b>	
Clamshell bracket	○
Front cover	○
Front dozer blade + rear outrigger	○
Front outrigger + rear dozer blade	○
Front outrigger + rear outrigger	○
Parking brake	●
Rear dozer blade	○
Rear outrigger	○
Right toolbox	○
Tire spacer	●
Toolbox: left chassis	●
Traction types pattern tires (10.00-20 16 PR)	●
4 tie down hooks	●

<b>FRONT ATTACHMENTS</b>	
Casted bucket link A	●
Centralized lubrication system	●
Dirt seal on all bucket pins	●
Flanged pin	●
HN bushing	●
Reinforced link B	○
Reinforced resin thrust plate	●
WC (tungsten-carbide) thermal spraying	●

<b>ATTACHMENTS</b>	
Accessories for 2 speed selector	○
Attachment basic piping	○
Breaker and crusher piping	○
HSB Parts for breaker and crusher	○
Pilot accumulator	●

<b>MISCELLANEOUS</b>	
Global e-Service	●
Onboard information controller	●
Standard tool kit	●
Travel direction mark on chassis frame	●





“ We develop construction machinery that contributes to the creation of affluent and comfortable societies ”

Kotaro Hirano, Hitachi Construction Machinery Co., Ltd.  
President and Executive Officer

## INSPIRED BY SOCIAL INNOVATION

Hitachi, Ltd. and its subsidiaries – including Hitachi Construction Machinery Co., Ltd. – are driven by a collective aim to contribute to social infrastructure development. Together, they provide reliable solutions to society’s challenges and meet the ever-changing needs of their customers around the world.

Established in 1910, Hitachi, Ltd. was built upon a philosophy of making a positive contribution to society through the development of original technology.

Today, it is one of the world’s largest corporations. By sharing its pioneering technological know-how with its subsidiaries it has created a diverse range of innovative products and services.

These include: IT and telecommunication, infrastructure systems, industrial systems,

construction, electronic devices and equipment, medical, scientific and laboratory equipment, high functional materials and components, automotive systems, financial and business services, and home electronics.

All of these products and services share a common aim that extends back to the company’s origins. They challenge convention, improve social infrastructure and contribute to the development of a more sustainable world.



Power systems and equipment



Automotive systems



Urban development





ASTACO (Advanced System with Twin Arm for Complex Operation)



Remote monitoring via Global e-Service and ConSite





**i** Hitachi construction machinery is manufactured and tested to the highest standards in production plants in Asia, Europe and North America.



# SOLID FOUNDATIONS

Hitachi Construction Machinery Co., Ltd. (HCM) has developed a comprehensive line-up of reliable construction equipment using its vast expertise and sharing the advanced technological capabilities of the Hitachi group.



AC drive technology enhances efficiency



Founded in 1970 as a Hitachi, Ltd. subsidiary, HCM has become one of the world's largest construction equipment suppliers. A pioneer in producing hydraulic excavators (from one-tonne minis to 800-tonne mining machines), HCM also manufactures wheel loaders, rigid dump trucks, crawler cranes and special application machines.

Suitable for a wide range of industries, Hitachi construction machinery helps to create infrastructure for safe and comfortable living, and in the development of natural resources. It can also be used to support disaster relief efforts, particularly

the ASTACO – a unique twin arm excavator specially developed for complex and delicate operations.

Incorporating advanced technology, Hitachi construction machinery benefits from synergies with other Hitachi, Ltd. companies. In the AC-3 range of dump trucks, for example, the AC drive system and the autonomous haulage system (AHS) have been developed to improve safety and efficiency in mines around the world. A further example is the remote monitoring systems available for Hitachi Zaxis excavators and ZW wheel loaders, developed to optimise performance.



Built on the foundation of superb technological capabilities, Hitachi Construction Machinery is committed to providing leading-edge solutions and services to contribute as a reliable partner to the business of customers worldwide.

---

Before using a machine with a satellite communication system or telecommunication system, please make sure that the satellite communication system complies with local regulations, safety standards and legal requirements. If not so, please make modifications accordingly.

---

These specifications are subject to change without notice. Illustrations and photos show the standard models, and may or may not include optional equipment, accessories, and all standard equipment with some differences in color and features. Before use, read and understand the Operator's Manual for proper operation.