

B20E

Low Ground Pressure • PIN 3

6x6

Articulated Dump Truck

Stage V Certified



- Net Power: 170 kW (228 hp)
- Heaped Capacity: 11 m³ (14,5 yd³)
- Rated Payload: 18 000 kg (39 683 lbs)
- Operating Weight: 35 999 kg (79 378 lbs)

BELL

B20E Low Ground Pressure



ENGINE

Manufacturer
Mercedes Benz (MTU)

Model
OM934LA / 4R 1000

Configuration
Inline 4, turbocharged and intercooled

Net Power
170 kW (228 hp) @ 1 800 rpm

Gross Torque
900 Nm (664 lbft)
@ 1 200 -1 600 rpm

Displacement
5,1 L (311 cu.in)

Auxiliary Brake
Compression brake

Fuel Tank Capacity
195 L (52 US gal)

AdBlue® Tank Capacity
31 L (8,2 US gal)

Certification
OM934LA meets EU Stage V emissions regulations

TRANSMISSION

Manufacturer
Allison

Model
Standard non-retarder:
3000P ORS
Optional retarder: 3000PR ORS

Configuration
Fully automatic planetary transmission with integral retarder.

Layout
Engine mounted

Gear Layout
Constant meshing planetary gears, clutch operated

Gears
6 Forward, 1 Reverse

Clutch Type
Hydraulically operated multi-disc

Control Type
Electronic

Torque Control
Hydrodynamic with lock-up in all gears

TRANSFER CASE

Manufacturer
Kessler

Series
W1400

Layout
Remote mounted

Gear Layout
Three in-line helical gears

Output Differential
Interaxle 33/67 proportional differential. Automatic inter-axle differential lock.

AXLES

Manufacturer
Bell

Model
15T

Differential
High input limited slip differential with spiral bevel gears

Final Drive
Outboard heavy duty planetary on all axles

BRAKING SYSTEM

Service Brake
Dual circuit, full hydraulic actuation wet disc brakes on front and middle axles.

Maximum brake force:
173 kN (38 892 lbf)

Park & Emergency
Spring applied, air released driveline mounted disc

Maximum brake force:
193 kN (43 388 lbf)

Auxiliary Brake
Jacobs Engine Brake®.
Option: Automatic, adjustable, integral, hydrodynamic transmission retarder. Output shaft speed dependent.

Total Retardation Power

Continuous: 178 kW (239 hp)
Maximum: 584 kW (783 hp)

WHEELS

Standard Type
Flotation

Tyre
800/45 R 30.5

Option Type
Radial Earthmover

Tyre
20.5 R 25

FRONT SUSPENSION

Semi-independent, leading A-frame supported by hydro-pneumatic suspension struts.

REAR SUSPENSION

Pivoting walking beams with laminated rubber suspension blocks.

HYDRAULIC SYSTEM

Full load sensing system serving the prioritized steering, body tipping and brake functions. A ground-driven, load sensing emergency steering pump is integrated into the main system.

Pump Type
Variable displacement load sensing piston

Flow
155 L/min (41 gal/min)

Pressure
310 Bar (4 500 psi)

Filter
5 microns

STEERING SYSTEM

Double acting cylinders, with ground-driven emergency steering pump.

Lock to lock turns
4,32

Steering Angle
45°

DUMPING SYSTEM

Two double-acting, single stage, dump cylinders

Raise Time
10 s

Lowering Time
5,5 s

Tipping Angle
70° standard, or any lower angle programmable

PNEUMATIC SYSTEM

Air drier with heater and integral unloader valve, serving park brake and auxiliary functions.

System Pressure
8,1 Bar (117 psi)

ELECTRICAL SYSTEM

Voltage
24 V

Battery Type
Two AGM (Absorption Glass Mat) type

Battery Capacity
2 X 75 Ah

Alternator Rating
28V 80A

VEHICLE SPEEDS

1st	6 km/h	4 mph
2nd	15 km/h	9 mph
3rd	19 km/h	12 mph
4th	27 km/h	17 mph
5th	36 km/h	22 mph
6th	42 km/h	26 mph
R	6 km/h	4 mph

CAB

ROPS/FOPS certified 74 dBA internal sound level measured according to ISO 6396.

Load Capacity & Ground Pressure

OPERATING WEIGHTS*		GROUND PRESSURE		LOAD CAPACITY		OPTION WEIGHTS	
UNLADEN	kg (lb)	LADEN (3" sinkage)		BODY	m³ (yd³)	kg (lb)	
Front	8 821 (19 450)	800/45 R 30.5	kPa (Psi)	Struck Capacity	9 (11)	Bin liner	778 (1 715)
Middle	4 742 (10 456)	Front	72 (10)	SAE 2:1 Capacity	11 (14,5)	Tailgate	633 (1 396)
Rear	4 436 (9 782)	Middle	95 (14)	SAE 1:1 Capacity	13,5 (17,5)	Extra wheelset	
Total	17 999 (39 688)	Rear	95 (14)	SAE 2:1 Capacity		800/45 R 30.5	338 (745)
		LADEN (No sinkage)		with Tailgate	11,5 (15)	Extra wheelset	
Front	10 621 (23 419)	20.5 R 25	kPa (Psi)			20.5 R 25	355 (783)
Middle	12 732 (28 074)	Front	215 (31)	Rated Payload	18 000 kg		
Rear	12 646 (27 885)	Middle	309 (45)		(39 683 lbs)		
Total	35 999 (79 378)	Rear	309 (45)				

* including additional equipment (tailgate)

Dimensions

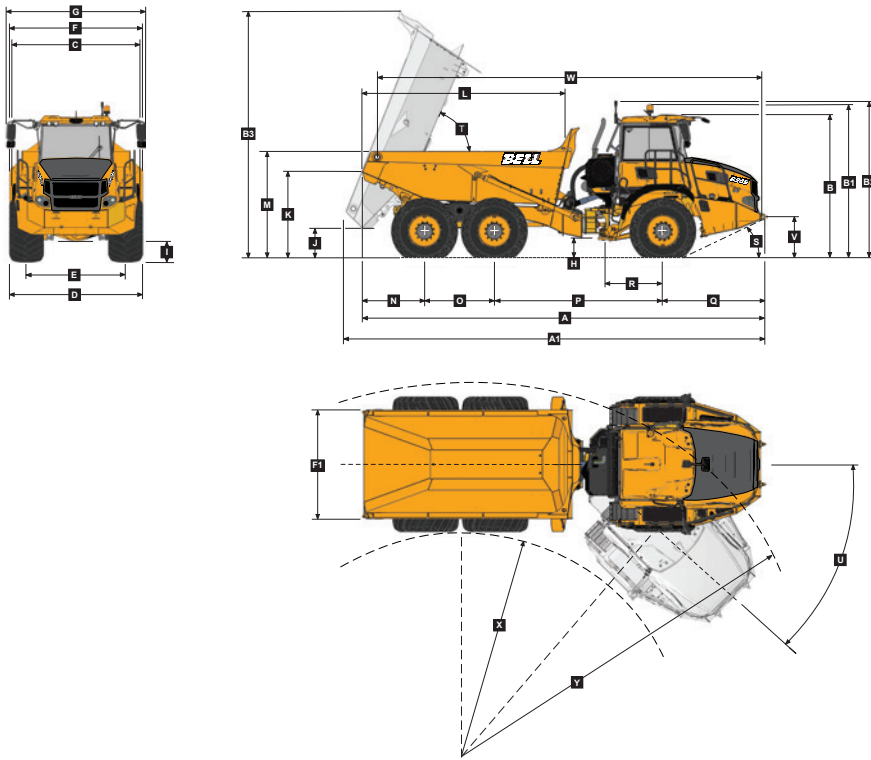

Machine Dimensions

A	Length - Transport Position	9271 mm	(30 ft. 5 in.)
A1	Length - Bin Fully Tipped	9560 mm	(31 ft. 4 in.)
B	Height - Transport Position	3385 mm	(11 ft. 1 in.)
B1	Height - Rotating Beacon	3619 mm	(11 ft. 10 in.)
B2	Height - Load Light	3702 mm	(12 ft. 2 in.)
B3	Bin Height - Fully Tipped	5742 mm	(18 ft. 10 in.)
C	Width over Mudguards	2984 mm	(9 ft. 9 in.)
D	Width over Tyres - 800/45-30.5	3102 mm	(10 ft. 2 in.)
D1	Width over Tyres - 20.5R25	2931 mm	(9 ft. 7 in.)
E	Tyre Track Width - 800/45-30.5	2312 mm	(7 ft. 7 in.)
E1	Tyre Track Width - 20.5R25	2399 mm	(7 ft. 10 in.)
F	Width over Bin	2540 mm	(8 ft. 4 in.)
F1	Width over Tailgate	2838 mm	(9 ft. 4 in.)
G	Width over Mirrors - Operating Position	3260 mm	(10 ft. 8 in.)
H	Ground Clearance - Artic	498 mm	(18,86 in.)
I	Ground Clearance - Front Axle	458 mm	(17,48 in.)
J	Ground Clearance - Bin Fully Tipped	678 mm	(26,38 in.)
K	Bin Lip Height - Transport Position	2067 mm	(6 ft. 9 in.)
L	Bin Length	4709 mm	(15 ft. 5 in.)
M	Load over Height	2537 mm	(8 ft. 4 in.)
N	Rear Axle Centre to Bin Rear	1449 mm	(4 ft. 9 in.)
O	Mid Axle Centre to Rear Axle Centre	1600 mm	(5 ft. 2 in.)
P	Mid Axle Centre to Front Axle Centre	3865 mm	(12 ft. 8 in.)
Q	Front Axle Centre to Machine Front	2357 mm	(7 ft. 8 in.)
R	Front Axle Centre to Artic Centre	1361 mm	(4 ft. 5 in.)
S	Approach Angle	27°	
T	Maximum Bin Tip Angle	70°	
U	Maximum Articulation Angle	45°	
V	Front Tie Down Height	1041 mm	(3 ft. 5 in.)
W	Machine Lifting Centres	8845 mm	(29 ft.)
X	Inner Turning Circle Radius-800/45-30.	3678 mm	(12 ft. 1 in.)
X1	Inner Turning Circle Radius-20.5R2	3763 mm	(12 ft. 4 in.)
Y	Outer Turning Circle Radius-800/45-30.	7585 mm	(24 ft. 11 in.)
Y1	Outer Turning Circle Radius-20.5R2	7499 mm	(24 ft. 7 in.)

Grade Ability/Rimpull

1. Determine tractive force by finding intersection of vehicle mass line and grade line. NOTE: 2% typical rolling resistance is already assumed in chart and grade line.
2. From this intersection, move straight right across charts until line intersects rimpull curve.
3. Read down from this point to determine maximum speed attained at that tractive resistance.

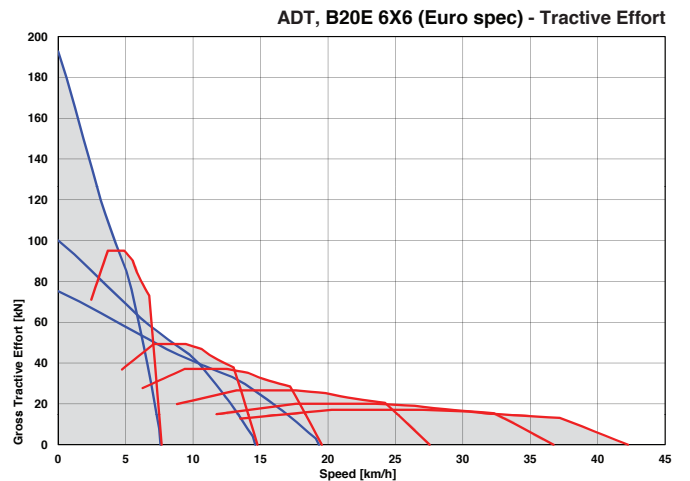
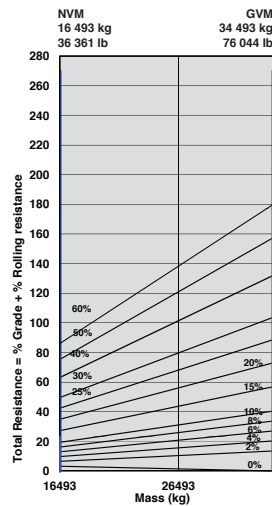

Retardation

1. Determine retardation force by finding intersection of vehicle mass line and grade line. NOTE: 2% typical rolling resistance is already assumed in chart and grade line.
2. From this intersection, move straight right across charts until line intersects the curve.
3. Read down from this point to determine maximum speed.

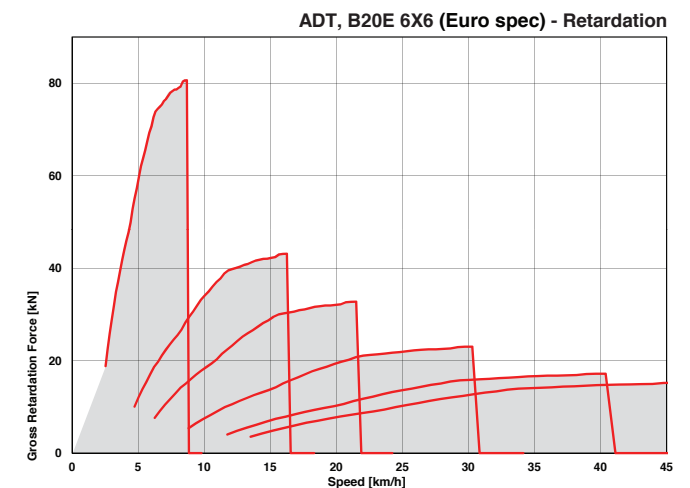
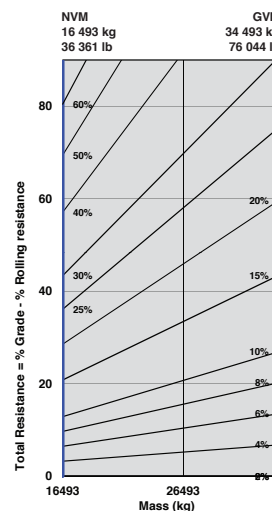

This curve is for a non-retarder transmission

ENGINE

- Jacobs Engine Brake®
- Dual element air cleaner with dust ejector valve
- Precleaner with automatic dust scavenging
- Water separator
- Serpentine drive belt with automatic tensioner
- Provision for fast fill

COOLING

- Crankshaft mounted electronically controlled viscous fan drive
- Fan guard

PNEUMATIC SYSTEM

- Engine-mounted compressor
- Air drier with heater
- Integral unloader valve

ELECTRICAL SYSTEM

- Battery disconnect
- Drive Lights
- Air Horn
- Reverse alarm
- ▲ White Noise reverse alarm
- Rotating Beacon
- Pitch Roll Sensor
- LED reverse lights
- ▲ LED Artic reverse lights
- ▲ Halogen Artic reverse lights

STEERING SYSTEM

- Bi-directional ground-driven secondary steering pump

CAB

- ROPS/FOPS certification
- Tilt cab
- Gas strut-supported door
- I-Tip programmable dump-body tip settings
- HVAC Climate control system
- AM/FM radio/CD player
- Rear window guard
- Wiper/washer with intermittent control
- Tilt and telescoping steering wheel
- Centre-mount air-suspension seat
- Halogen work Lights
- ▲ LED work lights
- ▲ Rotating beacon: seat belt installation
- ▲ Remote engine and machine isolation
- Remote battery jump start
- Retractable 3 point seat belt
- Heated seat
- Foldaway trainer seat with retractable seat belt
- 12-volt power outlet

CAB

- Cab utility bin (removable)
- Cup holder
- Cooled/heated lunch box
- Electric adjustable and heated mirrors
- Deluxe 10" colour LCD:
Speedometer / Fuel gauge /
Transmission oil temperature gauge /
Engine coolant temperature gauge /
LED function/warning indicators and audible alarm /
Transmission gear selection /
Tachometer / Battery voltage / Hour meter /
Odometer / Fuel consumption / Tip counter /
Trip timer / Trip distance / Metric/English units /
Service codes/diagnostics.
- Backlit sealed switch module functions with:
Wiper control / Lights / Heated mirrors /
Retarding aggressiveness / Transfer case differential lock /
Transmission gear hold /
Dump-body tip limit / Automatic dump-body tip settings /
Airconditioner/Heater controls /
Preselected Speed Control.

DUMP BODY

- ▲ Dump-body mechanical lock - fully up
- Dump-body mechanical lock - partially up
- ▲ Body liner
- ▲ Tailgate
- ▲ Body heater
- ▲ Less dump body and cylinders

OTHER

- Automation Traction Control (ATC)
- Wet disc brakes
- 800/45 R 30.5 Low Ground Pressure tyres
- ▲ 20.5 R 25 Radial Earthmover tyres
- ▲ Variably adjustable transmission retarder
- Remote grease banks
- ▲ Automatic greasing
- Onboard Weighing
- ▲ Load lights: stacks
- Reverse Camera
- ▲ Hand Rails
- Cab Peak
- ▲ High Pressure Hydraulic filter
- ▲ Fuel Heater
- Belly cover
- Cross member cover
- ▲ Remote transmission filters
- Fleetm@tic® Classic Package for 2 years
- ▲ Window smash button
- Electronic bonnet opening

The compilation of standard and optional equipment may vary by market region. Please check with your local distributor.

All dimensions are shown in millimetres, unless otherwise stated between brackets. Under our policy of continuous improvement, we reserve the right to change technical data and design without prior notice. Photographs featured in this brochure may include optional equipment.

BELL INTERNATIONAL: Tel: +27 (0)35-907 9431

E-mail: marketing@bellequipment.com

Web: www.bellequipment.com



Tel: +61 (0)8-9355-2442



Tel: +49 (0)6631 / 91-13-0



Tel: +27 (0)11-928-9700



Tel: +44 (0)1283-712862



Tel: +33 (0)5-55-89-23-56



Tel: +7-495-287-80-02



Tel: 1 (704) 655 2802

**Strong Reliable Machines
Strong Reliable Support**

BELL